

**JK-T1790**

**零件样本**

**PARTS BOOK**

**New JACK Sewing  
Machine**

**2013 年 4 月版**

**Revised edition in April, 2013**

## CONTENTS

### 目 录

1. FRAME & MISCELLANEOUS COVER COMPONENTS (1).....	1
头部·外装置部件 (1)	
2. FRAME & MISCELLANEOUS COVER COMPONENTS (2).....	3
头部·外装置部件 (2)	
3. MAIN SHAFT COMPONENTS.....	5
上轴部件	
4. HOOK DRIVING SHAFT COMPONENTS.....	7
下轴部件	
5. PRESSER & FEED COMPONETS.....	9
压脚·送料部件	
6. NEEDLE BAR ROCKING COMPONENTS.....	11
针杆摇动部件	
7. NEEDLE THREAD TRIMMER COMPONENTS.....	13
上剪线部件	
8. BOBBIN THREAD TRIMMER COMPONENTS.....	15
下剪线部件	
9. CLOTH CUTTING KNIFE COMPONENTS.....	17
切刀部件	
10. TABLE COMPONENTS.....	19
台板部件	
11. CONTROL BOX COMPONENTS.....	21
电控箱部件	
12. OPERATION BOX COMPONENTS.....	23
操作面板部件	
13. WIRING DLAGRAM.....	25
电装配线图	
14. ACCESSORIE PART COMPONENTS.....	27
附件	
15. THREAD STAND COMPONENTS.....	29
线架装置部件	
16. EXCHANGING PARTS.....	30
交换零件	
17. SPECIAL SPECIFICATIONS COMPONENTS.....	31
特殊类型部件	

# 1. FRAME & MISCELLANEOUS COVER COMPONENTS (1)

头部·外装置部件(1)

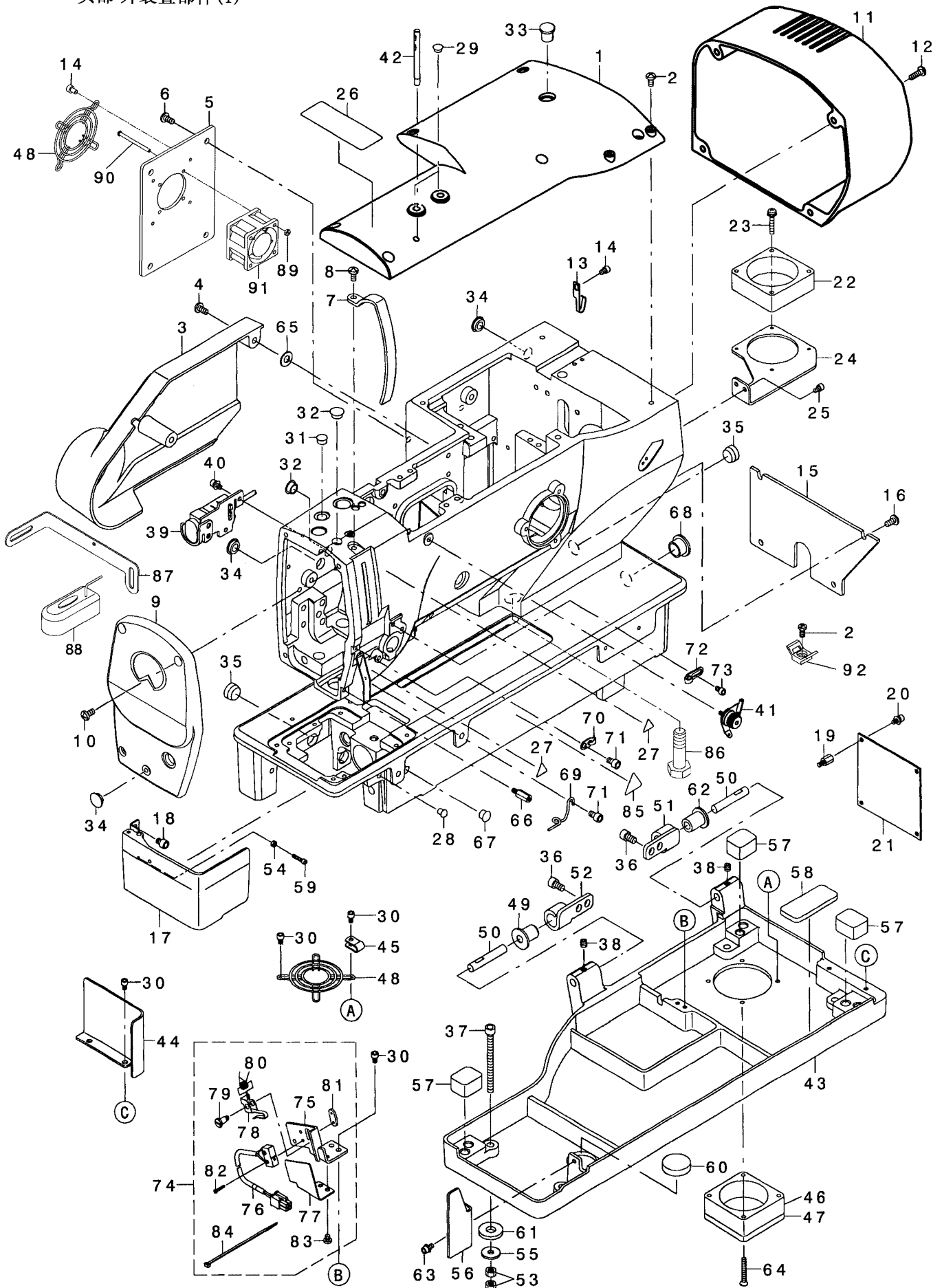

序号 NO	注解 Note	件号 Part NO.	名称	Description	数量 Qty
1		301282	上盖板	UPPER COVER	1
2		413S11002	螺钉	SCREW	7
3		301283	左盖板	LEFT COVER	1
4		413S11002	螺钉	SCREW	2
5		30284	左盖板B	LEFT COVER B	1
6		413S11002	螺钉	SCREW	4
7		301285	挑线杆保护板	THREAD TAKE UP LEVER COVER	1
8		413S11002	螺钉	SCREW	1
9		301286	前盖板	FRONT COVER	1
10		413S11002	螺钉	SCREW	3
11		301287	电机盖板	MOTOR COVER	1
12		413S11003	螺钉M5×16	SCREW M5 L=16	4
13		41312003	油管固定架	LUBRICATING OIL WICK STOPPER	1
14		413S13003	螺钉M4×6	SCREW M4 L=6	5
15		301288	后盖板	REAR COVER	1
16		413S11002	螺钉	SCREW	4
17		4130100500	防护板组件	HOOK OIL SHIELD COVER COMPL.	1
18		413S13001	螺钉M5×6	HEXAGON SOCKET HEAD SCREW M5×6	2
19		413S30007	定位螺钉	STLD	4
20		413S13008	螺钉组件	SCREW	4
21		41330001	电路板	INT PCB ASS'Y	1
22		41330002	电路板风扇	HEAD FAN MOTOR A ASS'Y	1
23		413S13025	螺钉组件	SCREW	2
24		41312007	风扇固定板	FAN FITTING PLATE	1
25		413S13003	螺钉M4×6	SCREW M4 L=6	2
26	*	41337001	安全标签	SAFETY LABEL	1
27		41337002	注意标签	ATTENTION SEAL	2
28		41322008	橡胶塞	RUBBER PLUG	1
29		41322009	橡胶塞	PLUG D=7.5 L=3.5	2
30		413S13003	螺钉M4×6	SCREW M=4 L=6	6
31		41322010	橡胶塞	RUBBER PLUG	1
32		41322012	橡胶塞	RUBBER PLUG	2
33		41322013	橡胶塞	RUBBER PLUG	1
34		41322014	橡胶塞	RUBBER PLUG D=12.5 L=4	3
35		41322015	橡胶塞	PLUG	2
36	01	413S13005	螺钉M6×10	SCREW M=6 L=10	4
37		413S13006	螺栓M6×70	HEXAGON BOLT	4
38		413S14001	螺钉M6×6	SCREW M=6 L=6	2
39		4133000300	开关组件	SWITCH ASM	1
40		413S13008	螺钉M4×8	SCREW	2
41		4131301400	张力控制组件	PRE-TENSION CONTROLLER ASM	1
42	01	41313013	过线轴	THREAD GUIDE BAR	1
43		41301006	油盘	BED BASE	1
44		301290	底座盖板	BED REAR COVER	1
45		41311001	线夹	CABLE CLAMP	1
46		41330004	油盘风扇	HEAD FAN MOTOR B ASS'Y	1
47		41311002	过滤器	FILTER	1
48		41312011	风扇挡板	FINGER GUARD	2
49	01	41303001	铰链套	HINGE BUSH	1
50		41326002	铰链销	HINGE PIN	2
51	01	41312012	铰链板	HINGE PLATE, A	1
52	01	41312013	铰链板	HINGE PLATE, B	1
53		413S16005	螺母M6	NUT M=6	8
54		413S16010	螺母M3×0.5	NUT M3×0.5	1
55		41328001	垫片	WASHER 6.1×18.5×2	4
56	01	41311003	防油罩	OIL SHIELD	1
57		41322001	橡胶垫	RUBBER C	3
58		41322002	垫板	RUBBER D	1
59		413S14012	螺钉	SCREW	1
60		41322017	橡胶	Z STOPPER RUBBER	1
61		41322003	橡胶垫片	RUBBER CLUSION (B)	4
62	01	41322004	橡胶铰链	RUBBER HINGE	1
63	01	413S13008	螺钉M4×10	SCREW	1
64		413S13009	螺钉M4×30	SCREW M4×0.7 L=30	2
65		41328002	垫片	CLOTH PLATE WASHER	2
66		413S30025	加长螺钉	VCS STLD A	1
67		41322011	橡胶塞	RUBBER PLUG	1
68		41322018	橡胶塞	RUBBER PLUG	1
69		41313001	过线钩	NEEDLE BAR THREAD GUIDE	1
70		41313002	左线钩	TAKE-UP THREAD GUIDE B	1
71		413S13010	螺钉M5×8	SCREW M5×0.8 L=8	2
72		41313003	右线钩	TAKE-UP THREAD GUIDE A	1
73		413S13003	螺钉M4×6	SCREW M=4 L=6	1
74		4133000400	安全开关组件	SAFETY SWITCH ASS'Y	1
75		41312084	安全开关座	SAFETY SW BASE	1
76		41330021	电线	SAFETY SWITCH CORD ASS'Y	1
77		41312085	安全开关盖板	SAFETY SWITCH COVER	1
78		40312132	安全开关臂	SAFETY SWITCH ARM	1
79		413S20011	轴位螺钉	SAFETY SWITCH ARM SHAFT	1
80		40327024	安全开关弹簧	SAFETY SWITCH SPRING	1
81		40312133	安全开关螺母	SAFETY SWITCH NUT	1
82		403S11050	螺钉	SCREW M=2 L=12	2
83		413S15004	螺钉	SCREW 9/64-40 L=4.5	2
84		40111005	固定带	CABLE BAND	1
85		41337002	注意标签	ATTENTION LABEL	1
86		413S12005	拼装螺栓	BOLT	4
87		41330029	LED灯安装板	LED FITTING PLATE	1
88		41330033	LED照明灯	LED	1
89		N01013	螺母	NUT	4
90		407S04056	螺钉	SCREW M3×40	4
91		41330071	风扇	FAN MOTOR	1
92		41311019	线夹	CABLE CLAMP	1

NOTE (注解) 01. . ACCESSORIE PART 附件

2. FRAME & MISCELLANEOUS COVER COMPONENTS (2)

头部·外装置部件(2)

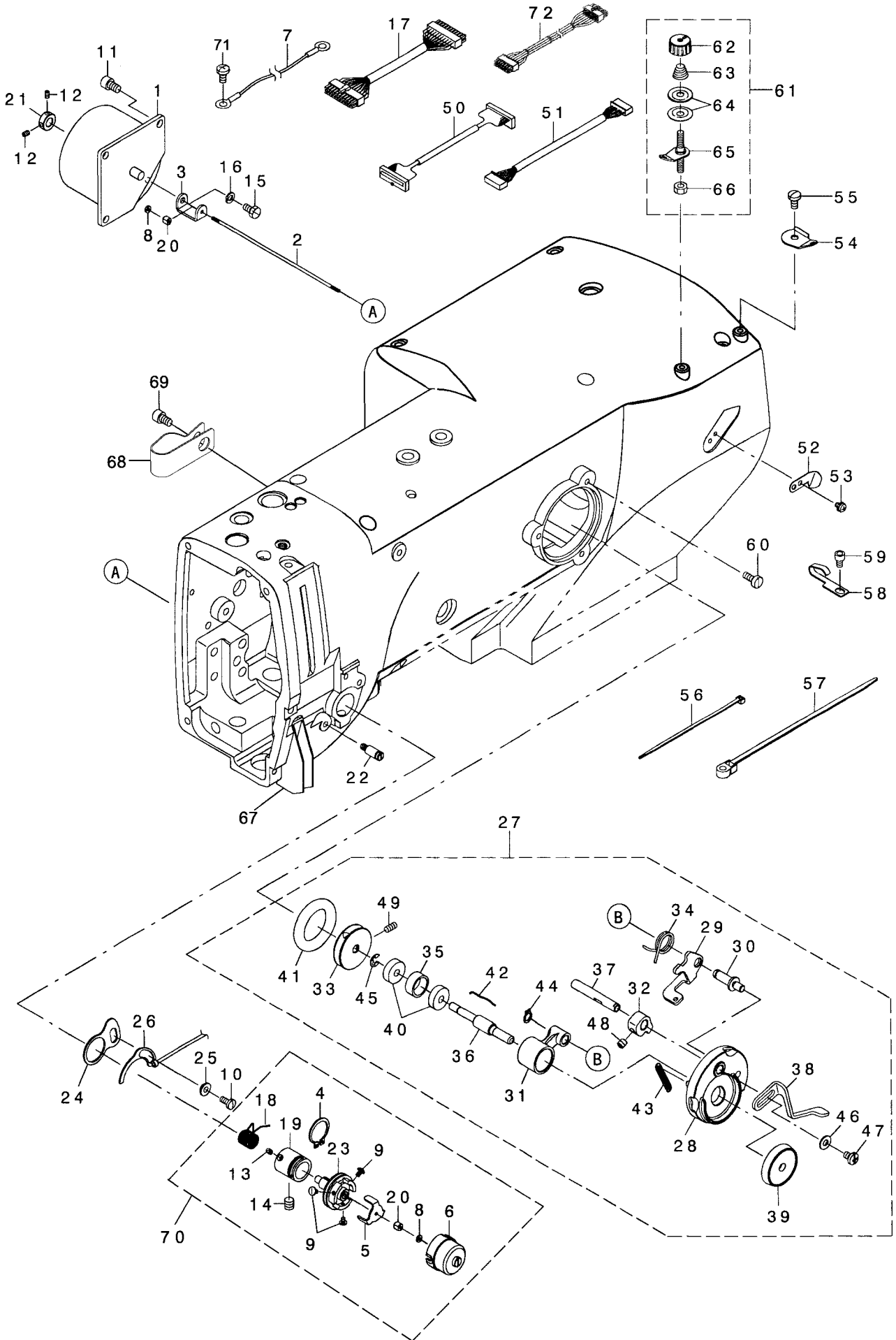

序号 NO	注解 Note	件号 Part NO.	名称	Description	数量 Qty
1		41330005	夹线电磁铁	ASSY AT SOLENOID	1
2		41312014	拉杆	AT SHAFT	1
3		41312015	拉杆固定架	AT SHAFT HOLDER	1
4		40329004	卡簧	RETAINING RING	1
5		40312123	松线止动卡盘	DISK STOPPER	1
6		40303024	夹线器帽	DISK STOPPER HOLDER CAP	1
7		41330022	接地线	EARTH CABLE ASM	1
8		413S16001	螺母	NUT	2
9		403S11048	螺钉	SCREW	3
10		413S30006	螺钉M4×8	SCREW M=4 L=8	1
11		413S13010	螺钉M5×8	SCREW M5×0.8 L=8	3
12		413S14004	定位环螺钉	SCREW	2
13		403S14015	螺钉	SCREW M3 L=4	1
14		413S14001	螺钉M6×6	SCREW M6 L=6	1
15		413S11023	螺钉	SCREW	1
16		W02002	弹簧垫片	SPRING WASHER	1
17		41330023	18芯电机电缆	INT CORD A ASS'Y	1
18		40327019	弹簧	TAKE-UP SPRING	1
19		40303025	夹线器座	THREAD TENSION POST BASE	1
20		41329002	卡圈	THREAD TENSION SHAFT COLLAR	2
21		41303002	定位环	THRUST COLLAR	1
22		413S30009	缓线钩定位螺钉	UTT SUSPENSION SCREW 9	1
23		4131300400	紧线器组件	ASSY THREAD TENSION POST	1
24		41311004	导板	GUIDE PLATE	1
25		41328005	尼龙垫片	BUSHING	1
26		41312018	接触片	THREAD BREAK DETECTOR A	1
27		4131300600	绕线器组件	ASSY BTW	1
28		40301026	盖板	BTW BASE	1
29		40312125	控制板	BTW CAM PLATE	1
30		40302014	绕线定位轴	BTW BASE SHAFT	1
31		40304013	绕线转动曲柄	BTW SHAFT BASE	1
32		40310008	转动卡头	BTW CAM LEVER	1
33		40303026	绕线转动板	BTW WHEEL	1
34		40327023	弹簧	BTW TORSION SPRING	1
35		40308012	挡圈	BTW BEARING SPACER	1
36		41302012	绕线器轴	BTW SHAFT	1
37		41302013	梭心压杆轴	BTW LEVER SHAFT	1
38		41312087	梭心压杆	BTW LEVER	1
39		41328021	梭心垫片	BTW SPACER	1
40		40324015	轴承	BTW BEARING	2
41		40322030	O形圈	BTW WHEEL RUBBER	1
42		40327021	梭心弹簧	BOBBIN SPRING	1
43		40327022	弹簧	BTW SPRING	1
44		40329005	卡簧	RETAINING RING	1
45		40329006	卡簧	E-RING 4	1
46		40328038	垫片	WASHER 4.5×10×0.8	1
47		403S11052	螺钉	SCREW	1
48		403S14022	螺钉	SCREW M5 L=5	1
49		403S14023	绕线转动板螺钉	SCREW M4×8	2
50		41330024	信号电缆	INT CORD D ASS'Y	1
51		41330025	8芯电磁铁电缆	INT CORD C ASS'Y	1
52		11419001	切线刀	THREAD CUTTER	1
53		413S11027	剪线刀螺钉组件	COMBINATION SCREW M3×5	2
54		41313007	导线器	THREAD GUIDE	1
55		413S11008	过线板螺钉	SCREW 11/64-40 L=7.8	1
56		40111005	固定带	CABLE BAND	10
57		40311023	固定带	CABLE BAND	2
58		41312003	润滑油管固定片	LUBRICATING OIL WICK STOPPER	3
59		413S13003	螺钉M4×6	SCREW M4 L=6	3
60		413S11004	螺钉M4×10	SCREW M4 L=10	3
61		4131300700	绕梭心夹线器组件	BOBBIN THREAD TENSION ASM	1
62		413S16013	塑料螺母	THREAD TESION NUT	1
63		41327017	弹簧	THREAD TESION SPRING	1
64		41313015	过线片	BOBBIN WINDER TENSION DISC	2
65		4131301800	过线销组件	BOBBIN THREAD TENSION ROD ASM	1
66		413S16012	螺母SM11/64 “×40	NUT 11/64-40	1
67		41312021	导线槽	THREAD GUIDE	1
68		41312089	线夹	CLAMP	1
69		413S13010	螺钉M5×8	SCREW M5 L=8	1
70		4131301900	夹线器组件	THREAD TENSION ASM	1
71		403S11013	螺钉	SCREW	1
72		41330039	12芯电机电缆	INT CORD B ASS'Y	1

### 3. MAIN SHAFT COMPONENTS

上轴部件

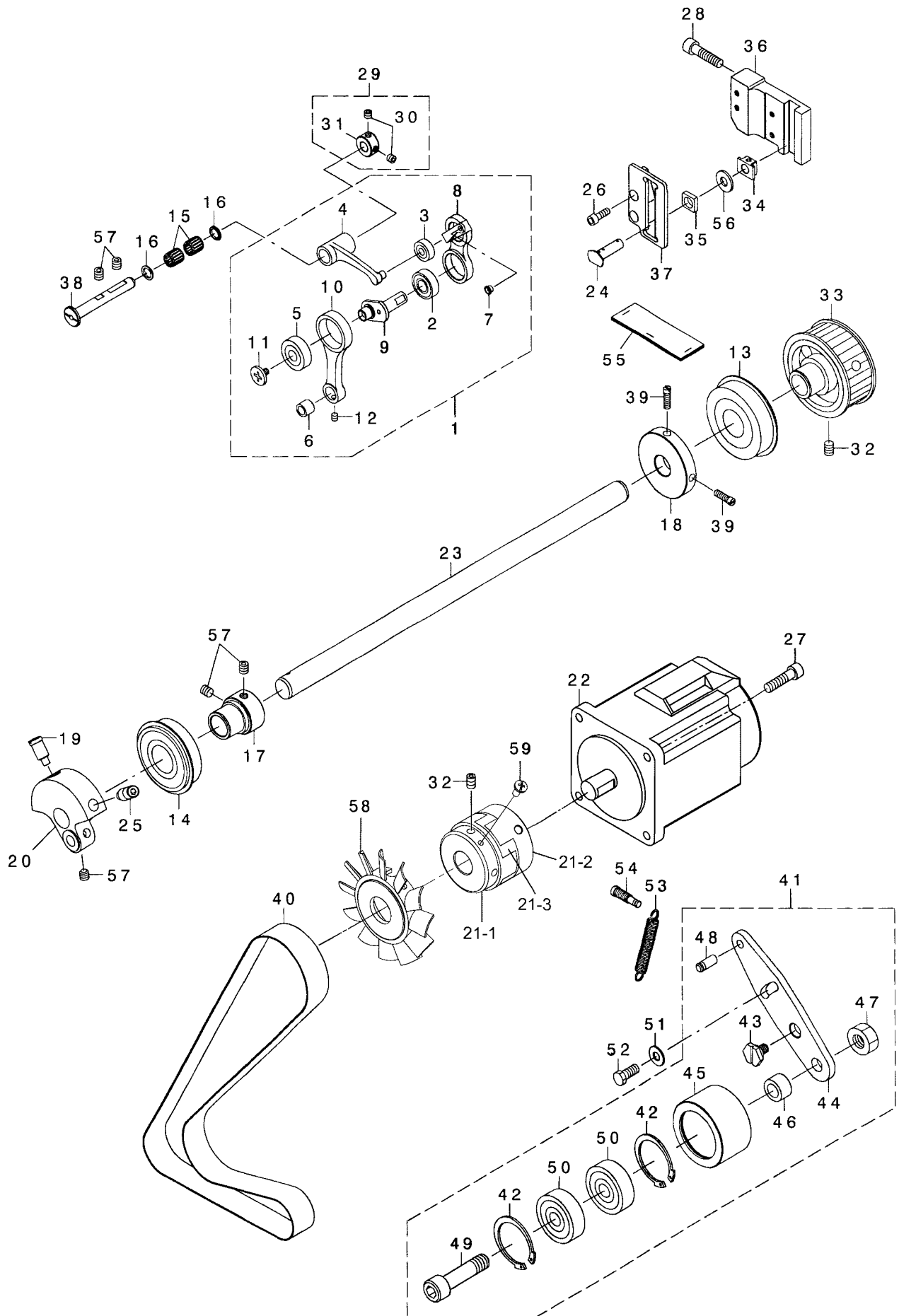

序号 NO	注解 Note	件号 Part NO.	名称	Description	数量 Qty
1		4133800100	挑线杆组件	THREAD_TAKE_UP_ASM	1
2		41324001	挑线曲柄轴承	BEARING	1
3		41324002	挑线连杆轴承	BEARING	1
4		41338001	挑线连杆	THREAD_TAKE_UP_CRANK	1
5		41324003	针杆连杆轴承	BUSHING	1
6		41303004	针杆连杆衬套	BUSH	1
7		41313009	过线套	THREAD_PASS_BUSH	1
8		4133800200	挑线杆组件	LINK_TAKE_UP	1
9		41338003	挑线曲柄	NEEDLE_BAR_CRANK	1
10		4130500100	针杆连杆组件	NEEDLE_BAR_CRANK_ROD	1
11		403S30011	螺钉	LEFT SCREW	1
12		413S14006	螺钉M4×4	SET SCREW M4 L=4	1
13		41324004	上轴后轴承	BEARING	1
14		41324005	上轴前轴承	BEARING	1
15		41324006	滚针轴承	BEARING	2
16		40322025	封油垫片	BEARING_SUPPORT	2
17		41303005	轴承固定套	BEARING HOLDER	1
18		40335002	绕线轮	BOBBIN_WINDER_DRIVING_WHEEL	1
19		413S30011	固定螺钉	COUNTER_WEIGHT_SCREW	1
20		41304001	针杆曲柄	COUNTER_WEIGHT	1
21-1		40301023	传动连接块	COUPLING_1	1
21-2		40301024	传动连接块	COUPLING_2	1
21-3		40322028	减震橡胶	DAMPING_RUBBER	1
22		41330006	主轴伺服电机	AC_SERVO_MOTOR	1
23		41302001	上轴	MAIN_SHAFT	1
24		41326003	滑块轴	NEEDLE_CRANK_SHAFT	1
25		413S30012	螺钉M8×16	SCREW M8 L=16	1
26		413S13011	螺钉M4×12	SCREW M4×0.7 L=12	2
27		413S13012	螺钉M5×20	SCREW M5 L=20	4
28		413S13013	螺钉M6×25	SCREW M6 L=25	3
29		-----	挡圈组件	THRUST_COLLAR_ASM	1
30		114S14001	挡圈螺钉	SCREW	2
31		40308006	挡圈	THRUST_COLLAR	1
32		403S14005	连接块螺钉	SCREW M6 L=8	6
33		4133500100	上同步带轮组件	SPROCKET_A	1
34		41309001	导向滑块	SQUARE_BLOCK	1
35		41309002	导向滑块	SQUARE_BLOCK	1
36		41309003	针杆导向板	SQUARE_BLOCK_GUIDE	1
37		41309004	针杆导向板B	SQUARE_BLOCK_GUIDE_B	1
38		41326004	挑线连杆轴	THREAD_TAKE_UP_CRANK_SHAFT	1
39		403S14008	绕线轮螺钉	SCREW M5 L=8	2
40		41335002	同步带	TIMING_BELT	1
41		4133500300	皮带张紧轮组件	IDLER_ASM	1
42		41329003	卡簧	RETAINING_RING	2
43		413S12001	螺钉	HINGE_SCREW	1
44		41312022	张紧轮安装板	IDLER_FIXED_PLATE	1
45		41303008	张紧轮	IDLER_PULLEY	1
46		41303009	挡圈	INTERMEDIATE_SPROCKET_WASHER	1
47		413S16009	螺母M10	NUT M10	1
48		41326005	挂簧销	FEED_LEVER_SPRING_HOOK	1
49		413S13014	螺钉M10×42.5	SCREW M10 L=42.5	1
50		41324007	轴承	BALL_BEARING	2
51		41328008	垫片	WASHER	1
52		413S12002	螺钉M6×14	SCREW M6 L=14	1
53		41327003	调整弹簧	ADJUSTING_SPRING	1
54		413S30013	挂簧螺钉	SUSPENSION_SCREW	1
55		41323001	润滑毡	NEEDLE_BAR_CRANK_FELT	1
56		41328022	垫片	WASHER	1
57		413S14001	螺钉M6×6	SCREW M6 L=6	6
58		40311302	叶轮	FAN	1
59		413S13016	螺钉	SCREW	3



#### 4. HOOK DRIVING SHAFT COMPONENTS

下轴部件

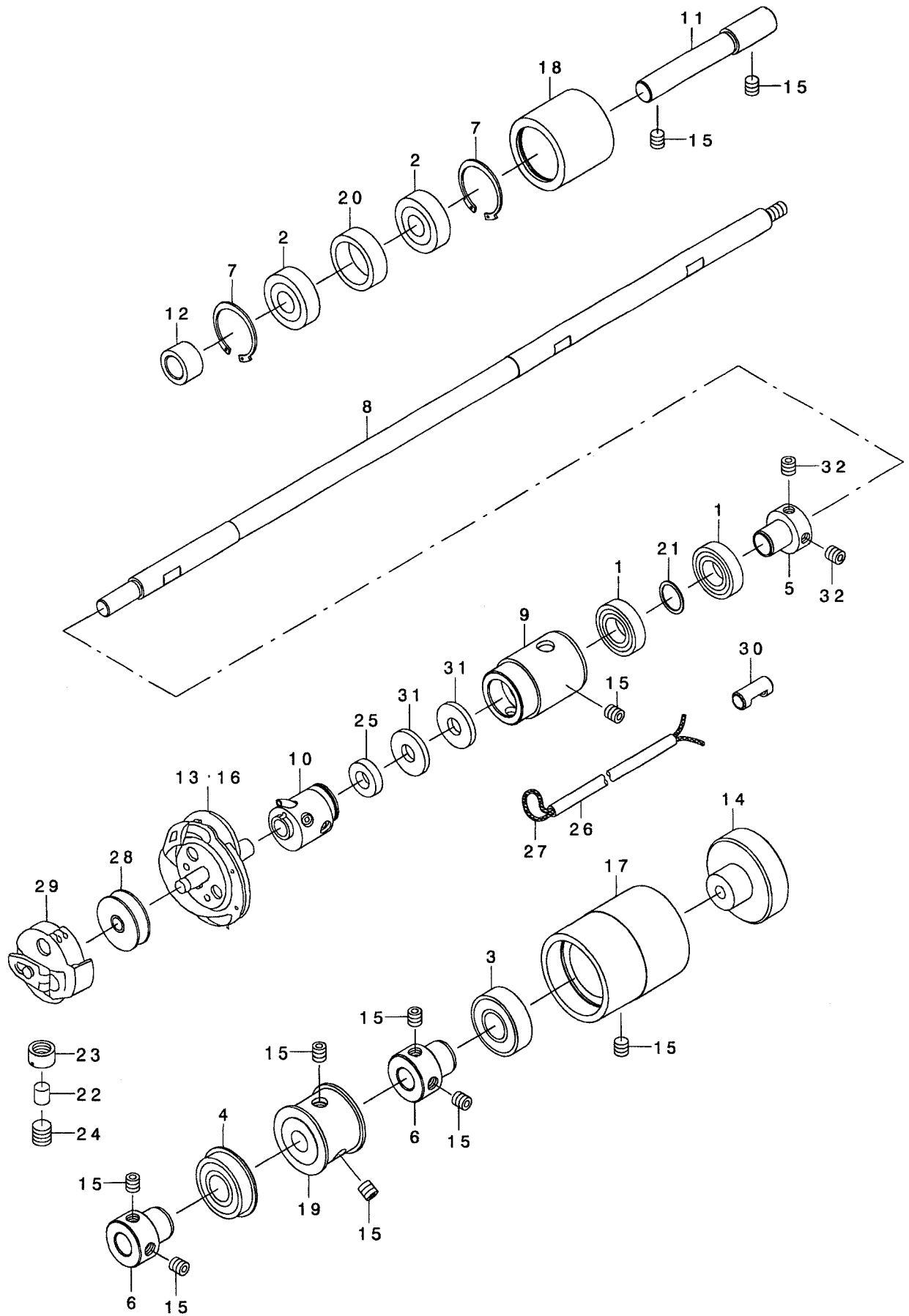

序号 NO	注解 Note	件号 Part NO.	名称	Description	数量 Qty
1		41324008	轴承	BEARING	2
2		41324009	轴承	BALL BEARING	2
3		41324010	轴承	BEARING	1
4		41324011	轴承	BEARING	1
5		41303010	轴承固定套	BEARING SUPPORT	1
6		41303011	轴承固定套	BUSH	2
7		41329004	卡簧	RETAINING RING	2
8		41302002	下轴	HOOK_DRIVING_SHAFT	1
9		41303012	下轴前轴套	HOOK_DRIVING_SHAFT_METAL	1
10		4130301300	旋梭连接套组件	HOOK_SLEEVE_ASM	1
11		41335003	中同步带轮轴	INTERMEDIATE_SPROCKET_SHAFT	1
12		41303009	挡圈	INTERMEDIATE_SPROCKET_WASHER	1
13	01	41318001	旋梭(790)	HOOK_COMPL	1
14		4131101100	手轮组件	CROWN_KNOB	1
15		413S14001	螺钉M6×6	SCREW M6 L=6	10
16	02	41318002	旋梭(791K)	HOOK_COMPL (K)	1
17		41303014	下轴后轴套	BEARING_SUPPORT	1
18		41335004	中同步带轮	SPROCKET_B	1
19		4133500600	下同步带轮组件	SPROCKET_C	1
20		41303015	垫圈	INTERMEDIATE_SPROCKET_RING	1
21		41328009	垫圈	WASHER	1
22		41326007	调整杆	ADJUSTING_SHAFT	1
23		413S30002	调整螺母	ADJUSTING_NUT	1
24		413S15001	旋梭油量调节螺钉	SCREW M8×8	1
25		41323002	油毡	FELT	1
26		40321001	油管	TUBE	1
27		12923021	油线	OIL_WICK	1
28		4021800200	梭心	BOBBIN	1
29		41318003	梭壳	BOBBIN_CASE_ASM	1
30		41303016	油量控制架	PIPE	1
31		41323003	油毡	OIL_FILTER	2
32		207S14006	螺钉	SCREW M5 L=5	2
NOTE (注解)			01. . .FOR 1790S	1790S用	
			02. . .FOR 1790K	1790K用	

# 5. PRESSER & FEED COMPONENTS

压脚·送料部件

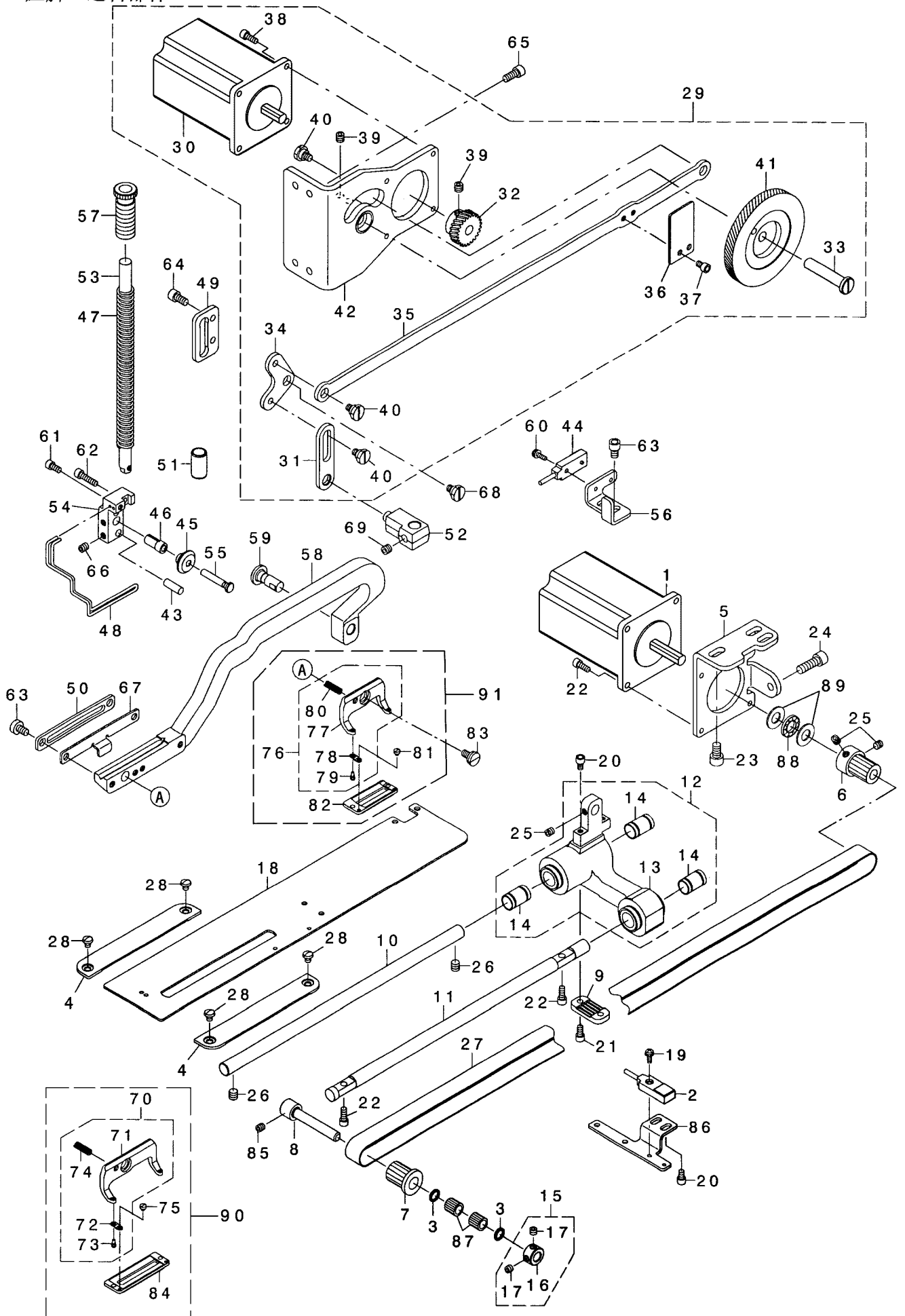

序号 NO	注解 Note	件号 Part NO.	名称	Description	数量 Qty
1		41330007	送布马达	FEED MOTOR ASS'Y	1
2		41330008	送布传感器	FEED SENSOR ASS'Y	1
3		40322025	封油垫片	BEARING SUPPORT	2
4		41312023	固定板	THROAT PLATE BASE COVER	2
5		41312024	送料步进电机固定架	MOTOR BRACKET	1
6		4133500700	送料后同步带轮组件	PULLEY B	1
7		4133500900	送料前同步带轮组件	PULLEY C	1
8		41326008	送料前同步带轮轴	SUPPORT SHAFT	1
9		401012	固定板	TIMING BELT HOLDER	1
10		41302003	支架轴	FEED SHAFT	1
11		41302004	送布支架导向轴	FEED GUIDE SHAFT	1
12		4130400100	送布支架组件	FEED BASE ASM	1
13		401013	送布支架	FEED BASE	1
14		41324014	送布支架轴承	SLIDE BEARING	3
15		-----	挡圈组件	THRUST COLLAR ASM	1
16		40308006	挡圈	THRUST COLLAR	1
17		114S14001	螺钉	SCREW	2
18		41312026	拖板	WORK CLAMP CARRIER	1
19		413S13026	螺钉组件	SCREW M3×10	1
20		413S13016	螺钉M4×6	SCREW M4 L=6	4
21		413S13016	螺钉M4×8	SCREW M4×0.7 L=8	2
22		413S13017	螺钉M4×10	SCREW M4 L=10	6
23		413S13005	螺钉M6×10	SCREW M6 L=10	3
24		413S13018	螺钉M6×18	SCREW M6 L=18	1
25		207S14006	螺钉	SCREW M5 L=5	3
26		413S14001	螺钉M6×6	SCREW M6 L=6	2
27		41335007	送布同步带	TIMING BELT	1
28		413S11009	螺钉M4×5	SCREW M4 L=5	4
29		4133001200	拾压脚组件	ASSY PBL GEAR MODULE	1
30		41330009	拾压脚步进电机	CLAMP MOTOR ASS'Y	1
31		41312028	压脚导向连接板	PBL FRONT LINK	1
32		41325001	压脚升降齿轮B	PBL GEAR S	1
33		41326009	齿轮轴	PBL GEAR SHAFT	1
34		41312029	压脚升降摆动板	PBL L LINK	1
35		41305002	压脚升降拉杆	PBL LONG ROD	1
36		41312030	传感器板	PBL SENSOR PLATE	1
37		413S13003	螺钉M4×6	SCREW M4 L=6	2
38		413S13017	螺钉M4×10	SCREW M4 L=10	4
39		413S14003	螺钉M6×5	SCREW M6 L=5	5
40		413S20001	压脚升降摆动板螺钉	SHOULDER SCREW D8 H3.2	4
41		4132500200	压脚升降齿轮A组件	ASSY PBL GEAR L	1
42		4131203500	压脚电机安装板组件	ASSY PBL MOTOR BASE	1
43		41326010	压脚支架固定轴	PIN, SHORT	1
44		41330010	传感器	CLAMP SENSOR ASS'Y	1
45		41309005	滑轮	SLIDE ROLLER	1
46		41303018	衬套	COLLAR	1
47		41327004	压脚杆弹簧	PBL COLL SPRING	1
48		41327005	防护簧	PBL FINGER GUARD	1
49		41312032	压脚杆滑槽	PBL GUIDE	1
50		41312033	压脚前后送料导向板	PBL LIFTING PLATE	1
51		41303019	压脚杆套	PBL METAL	1
52		41304003	压脚杆升降支架	PBL POSITION BRACKET	1
53		41302005	压脚轴	PBLPRESSER BASE	1
54		401015	滑轮支架	PBL ROLLER BASE	1
55		41326011	滑轮轴	PBL ROLLER SHAFT	1
56		41312034	传感器安装板	PBL SENSOR BASE	1
57		413S30003	弹簧调节螺母	PBL SPRING REGULATOR	1
58		41316001	压脚支架	PBL WORK CLAMP ARM	1
59		41326012	曲柄轴	PBL WORK CLAMP ARM SHAFT	1
60		413S13026	螺钉M3×10	SCREW M3×10	1
61		413S13016	螺钉M4×8	SCREW M4×0.7 L=8	1
62		413S13020	螺钉M4×16	SCREW M4×0.7 L=16	1
63		413S11018	螺钉M5×8	SCREW M5 L=8	2
64		413S11019	螺钉M5×10	SCREW M5×0.8 L=10	4
65		413S13019	螺钉M5×12	SCREW M5×0.8 L=12	4
66		413S14013	螺钉M5×6	SCREW M5 L=6	2
67		41312035	剪线板	UTT CLOSE CAM B	1
68		413S20001	压脚升降摆动板螺钉	SHOULDER SCREW D8 H3.2	1
69		413S14003	螺钉M6×5	SCREW M5 L=6	1
70		4131602000	压脚组件	WORK CLAMP CHECK HOLDER	1
71		41316018	压脚板座	WORK CLAMP CHECK HOLDER	1
72		41312109	压脚弹簧板	WORK CLAMP CHECK SPRING	2
73		41326035	压脚弹簧定位销	WORK CLAMP CHECK SPRING SET PI	2
74		41327020	压脚板座弹簧	WORK CLAMP CHECK HOLDER SPRING	1
75		413S11029	螺钉	SCREW 3/32-56 L=1.9	2
76		4131602200	压脚组件	WORK CLAMP CHECK HOLDER ASM	1
77		41316023	压脚板座	PRESSER FOOT	1
78		41312109	压脚弹簧板	WORK CLAMP CHECK SPRING	2
79		41326035	压脚弹簧定位销	WORK CLAMP CHECK SPRING SET PI	2
80		41327020	压脚板座弹簧	WORK CLAMP CHECK HOLDER SPRING	1
81		413S11029	螺钉	SCREW 3/32-56 L=1.9	2
82		41316024	压脚板	PRESSER	1
83		402S20002	压脚螺钉	HINGE SCREW D=7.94 H=2	1
84		41316019	压脚板	WORK CLAMP CHECK (2K)	1
85		207S14006	螺钉	SCREW M5 L=5	1
86		41312027	传感器定位板	SENSOR PLATE	1
87		41324006	滚针轴承	BEARING	2
88		41324013	轴承	BEARING	1
89		41328026	垫片	WASHER	2
90		4131602100	压脚组件	WORK CLAMP CHECK HOLDER ASM	1
91		4131602600	压脚组件	WORK CLAMP CHECK HOLDER ASM	1

## 6. NEEDLE BAR ROCKING COMPONENTS

针杆摇动部件

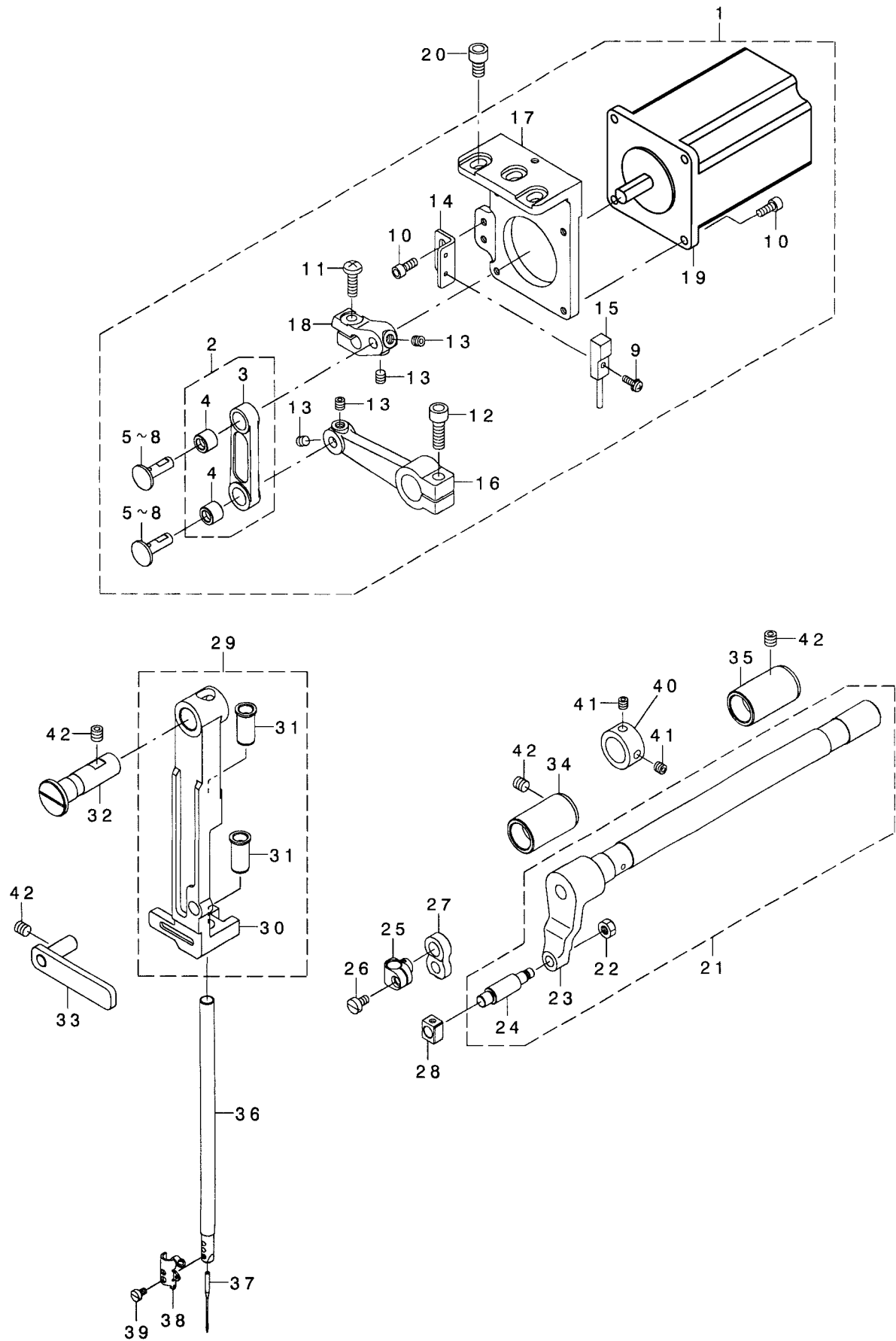

序号 NO	注解 Note	件号 Part NO.	名称	Description	数量 Qty
1		4133001500	摆轴驱动组件	ZIGZAG DRIVE FULL ASSY	1
2		4130500300	摆轴连杆组件	ZIGZAG ROD ASM	1
3		41305003	摆轴连杆	ZIGZAG ROD	1
4		41303020	轴套	SHAFT HOLDER LINK BUSH	2
5	01	41326013	连接轴A	JUNCTION SHAFT A	2
6	01	41326014	连接轴B	JUNCTION SHAFT B	2
7	01	41326015	连接轴C	JUNCTION SHAFT C	2
8	01	41326016	连接轴D	JUNCTION SHAFT D	2
9		413S13026	螺钉M3×10	SCREW M3×10	1
10		413S13017	螺钉M4×10	SCREW M4 L=10	6
11		413S11003	螺钉M5×16	SCREW M5 L=16	1
12		413S13018	螺钉M6×18	SCREW M6 L=18	1
13		207S14006	螺钉	SCREW M5 L=5	4
14		41312036	传感器固定板	SENSOR PLATE	1
15		41330011	针摆传感器	NEEDLE SWING SENSOR ASSY	1
16		41304005	针杆摆动曲柄	ZIGZAG LEVER REAR	1
17		41301007	电机安装板	MOTOR_BASE	1
18		41304006	电机连接曲柄	MOTOR_LEVER	1
19		41330012	针摆步进电机	NEEDLE SWING SENSOR ASS'Y	1
20		413S13005	螺钉M6×10	SCREW M6 L=10	3
21		4130200600	摆轴组件	ZIGZAG LEVER SHAFT ASM	1
22		413S16004	螺母 M5	NUT M5	1
23		41302006	摆轴	ZIGZAG LEVER SHAFT	1
24		41326017	摆轴驱动轴	ZIGZAG_STUD	1
25		41304007	针杆连接杆	NEEDLE BAR CONNECTION	1
26		413S11010	针杆连接螺钉	SCREW M4 L=7	1
27		41305004	针杆连杆	NEEDLE BAR ROD	1
28		41309006	针杆架滑块	SQUARE BLOCK	1
29		4130100900	针杆架组件	NEEDLE BAR FRAME ASSY	1
30		401016	针杆架	NEEDLE BAR FRAME	1
31		41303021	针杆衬套	NEEDLE BAR METAL	2
32		41326018	针杆架连接轴	SUPPORT_SHAFT	1
33		401017	针杆架压板	FRAME SUPPORT PLATE ASM	1
34		41303022	摆轴前套	BUSHING	1
35		41303023	摆轴后套	BUSHING REAR	1
36		41302007	针杆	NEEDLE BAR	1
37		40217002	机针	NEEDLE DP×5 #12	1
38		41313010	面线导线器	NEEDLE BAR BOBBIN THREAD GUIDE	1
39		413S11011	螺钉M3×5	SCREW M3 L=5	1
40		41308003	摆轴挡圈	THRUST COLLAR D=15 W=11	1
41		207S14006	螺钉	SCREW M5 L=5	2
42		413S14001	螺钉M6×6	SCREW M6 L=6	4

NOTE (注解) 01...SELECTIVE PARTS 选用零件

7. NEEDLE THREAD TRIMMER COMPONENTS

上剪线部件

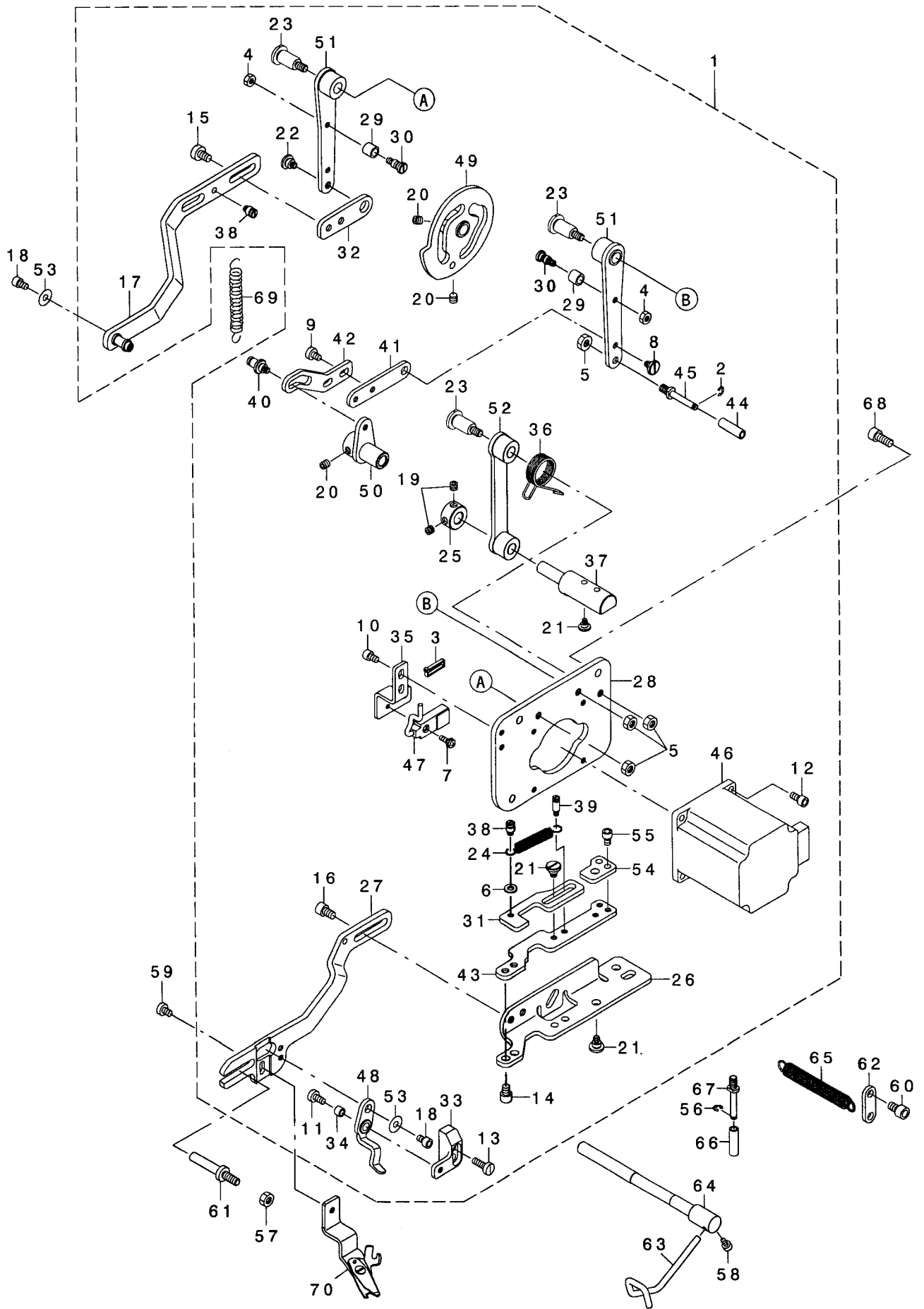

序号 NO	注解 Note	件号 Part NO.	名称	Description	数量 Qty
1		4131900100	剪面线组件	ASSY_UTT_MODULE_B	1
2		H05002	E形卡簧	E-RING 3	1
3		40111005	固定带	CABLE BAND	1
4		413S16002	螺母 M4	NUT M4	2
5		413S16004	螺母 M5	NUT M5	4
6		41328010	垫片	WASHER 4.3×9×0.8	1
7		413S13026	螺钉M3×10	SCREW M3×10	1
8		413S20003	固定板连接螺钉	SHOULDER SCREW D6 H2.6	1
9		413S11017	螺钉M4×6	SCREW M4 L=6	2
10		413S13003	螺钉M4×6	SCREW M4 L=6	2
11		413S30006	螺钉M4×8	SCREW M4 L=8	1
12		413S13016	螺钉M4×8	SCREW M4×0.7 L=8	4
13		413S12003	螺钉M4×12	SCREW M4 L=12	2
14		413S13001	螺钉M5×6	HEXAGON SOCKET HEAD SCREW M5×6	2
15		413S11018	螺钉M5×8	SCREW M5 L=8	2
16		413S13010	螺钉M5×8	SCREW M5×0.8 L=8	2
17		4131204400	开剪连杆组件	ASSY_UTT_RELEASE_ARM_B	1
18		413S13003	螺钉M4×6	SCREW M4 L=6	2
19		207S14006	螺钉M5×4	SCREW M5 L=4	2
20		207S14006	螺钉	SCREW M5 L=5	4
21		413S30014	剪线导向板调节螺钉	SHOULDER SCREW D6 H3.2	4
22		413S20004	剪线连接板螺钉	SHOULDER SCREW D8 H4	1
23		413S20005	剪线曲柄螺钉	SHOULDER SCREW D8 15	3
24		41327006	导向板弹簧	SPRING	1
25		41308004	剪线支架连接销挡圈	THRUST COLLAR D=8 W=9	1
26		41312039	剪线支架	UTT_ARM_A	1
27		41312040	剪刀架	UTT_ARM_B	1
28		41312041	剪线电机安装板	UTT_BASE_PLATE	1
29		41303024	滚柱	UTT_CAM_ROLLER	2
30		413S30015	滚子连接螺钉	UTT_CAM_ROLLER_SHAFT	2
31		41312091	剪刀进退导向板	UTT_RATCH_PLATE_B	1
32		41312043	剪线连接板	UTT_RELEASE_ARM_A	1
33		41304008	开剪驱动板安装座	UTT_RELEASE_LEVER_BASE	1
34		41303025	连接滚子	UTT_RELEASE_LEVER_SHAFT	1
35		41312044	传感器安装板	UTT_SENSOR_BASE	1
36		41327007	扭簧	UTT_SUPPORT_ARM_SPRING	1
37		41326021	剪线支架连接轴	UTTSUPPORT_SHAFT	1
38		413S30016	螺钉	UTT_SUSPENSION_SCREW_4	2
39		413S30009	缓线钩定位螺钉	UTT_SUSPENSION_SCREW_9	1
40		413S30018	缓线连接销	UTT_SUSPENSION_SHOULDER_SCREW	1
41		41312045	缓线钩连接板	UTT_THREAD_PULLING_LINK_A	1
42		41312046	缓线钩驱动板	UTT_THREAD_PULLING_LINK_B	1
43		41312047	剪刀进退固定板	UTT_X-CAM	1
44		41303026	滚柱	UTT_Y-DRIVE_ROLLER	1
45		41326032	滚轴	UTT_Y-DRIVE_SHAFT	1
46		41330013	剪面线步进电机	UT_TRIM_MOTOR_ASS'Y	1
47		41330014	剪线传感器	UT_TRIM_SENSOR_ASS'Y	1
48		4131205500	开剪驱动板组件	ASSY_UTT_RELEASE_LEVER_B	1
49		4131205700	剪线凸轮组件	ASSY_UTT_CAM	1
50		4130401100	缓线钩连接曲柄组件	ASSY_UTT_THREAD_PULLING_ARM	1
51		4130401200	缓线钩导向曲柄组件	ASSY_UTT_CAM_ARM	2
52		4130401300	剪线连接曲柄组件	ASSY_UTT_SUPPORT_ARM	1
53		41328012	垫圈	PLAIN WASHER 4.3×12×1	2
54		41312088	限位板	UTT_RATCH_STOPPER	1
55		413S13003	螺钉M4×6	SCREW M4 L=6	2
56		H05002	E形卡簧	E-RING 3	1
57		413S16004	螺母M5	NUT M5	1
58		413S13003	螺钉M4×6	SCREW M4 L=6	1
59		413S13003	螺钉M4×6	SCREW M4 L=6	1
60		413S13010	螺钉M5×8	SCREW M5×0.8 L=8	1
61		41326034	压脚导向轴	UTT_GUIDE_SHAFT_B	1
62		41312053	连接板	UTT_SUSPENSION_PLATE	1
63		41313011	缓线钩	UTT_THREAD_PULLING_LEVER	1
64		41302008	缓线钩轴	UTT_THREAD_PULLING_SHAFT	1
65		41327009	剪线弹簧	UTT_TRIMMER_CLOSE_SPRING	1
66		41303026	滚柱	UTT_Y-DRIVE_ROLLER	1
67		41326032	剪刀控制轴	UTT_Y-DRIVE_SHAFT	1
68		413S13019	螺钉M5×12	SCREW M5×0.8 L=12	3
69		41327008	缓线钩复位弹簧	BUTTON_SUPPORT_LEVER_SPRING	1
70		4131900200	上剪线刀组件	ASSY_UTT_TRIMMER	1



# 8. BOBBIN THREAD TRIMMER COMPONENTS

下剪线部件

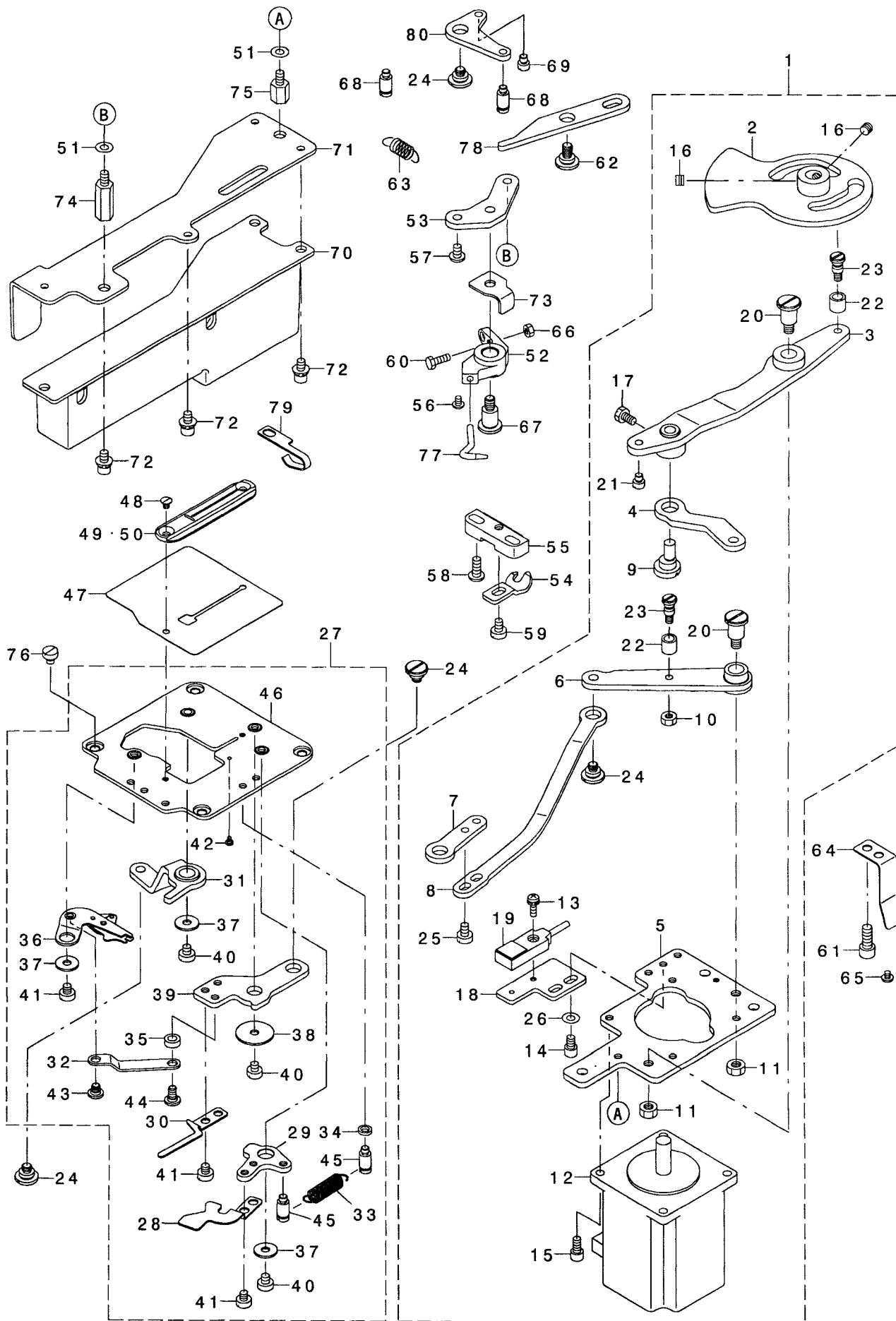

序号 NO	注解 Note	件号 Part NO.	名称	Description	数量 Qty
1		4133002000	剪底线组件	BTT DRIVE LMIT	1
2		4131206300	剪底线凸轮组件	ASSY BTT DRIVE CAM	1
3		4130500600	剪底线连杆组件	ASSY BTT DRIVE LEVER	1
4		41312056	剪底线连杆	BTT DRIVE LINK	1
5		41312057	底线电机安装板	BTT DRIVE LMIT BASE	1
6		4130401400	剪底线导向曲柄组件	ASSY BTT RELEASE LEVER	1
7		41312059	剪力调节板	BTT RELEASE LINK F	1
8		41312060	剪底线导向曲柄连杆	BTT RELEASE LINK R	1
9		41326023	偏心轴销	LINK ROD	1
10		413S16003	螺母M4	NUT M4	1
11		413S16004	螺母M5	NUT M5	2
12		41330015	剪底线步进电机	LT TRIM MOTOR ASS'Y	1
13		413S13026	螺钉M3×10	SCREW M3×10	1
14		413S13003	螺钉M4×6	SCREW M4 L=6	2
15		413S13016	螺钉M4×8	SCREW M4×0.7 L=8	4
16		207S14006	螺钉M5×4	SCREW M5 L=4	2
17		413S12004	螺钉M4×7	HEXAGONAL BOLT	1
18		41312061	传感器安装板	SENSOR FITTING PLATE BT	1
19		41330016	传感器	LT TRIM SENSOR ASS'Y	1
20		413S20006	轴位螺钉	SHOULDER SCREW D8 H10	2
21		413S30019	止动销	STOPPER PIN	1
22		41303024	滚柱	UTT CAM ROLLER	2
23		413S30015	滚子连接销	UTT CAM ROLLER SHAFT	2
24		413S20007	轴位螺钉	SHOULDER SCREW D8 H2.9	4
25		413S11017	螺钉M4×6	SCREW M4 L=6	2
26		41328010	垫圈	WASHER 4.3×9×0.8	2
27		4131500100	针板组件	THROAT PLATE BASE LMIT	1
28		41312062	剪线器压板	BT CLAMP B	1
29		41312063	固定板	BT CLAMP LEVER	1
30		41312064	底线导线器	BT PULLER B	1
31		4131207500	剪力控制板组件	ASSY BT RELEASE ARM	1
32		41312066	传动连接杆	BT TRIMER LINK	1
33		41327010	弹簧	CLAMP SPRING	1
34		41328011	垫圈	WASHER	1
35		41308005	垫圈	WASHER	1
36		4131900300	下剪线刀组件	BT TRIMER	1
37		41328013	垫圈	PLAIN WASHER 4.3×12×1	3
38		41328014	垫圈	WASHER 4.5×20×1	1
39		41312070	剪底线传动板	BTT LEVER	1
40		413S11013	螺钉	SCREW M4 L=4	3
41		413S11013	螺钉M4×4	SCREW M4 L=4	5
42		413S11014	螺钉	HINGE SCREW	1
43		413S20008	轴位螺钉	SHOULDER SCREW D5 H1.6	1
44		413S20009	轴位螺钉	SHOULDER SCREW D5 H1.6	1
45		413S30020	挂簧螺钉	SUSPENSION SCREW	2
46		4131206800	剪线组件安装板	ASSY THROAT PLATE BASE	1
47		41312067	防油板	OIL SHIELD	1
48		413S17002	螺钉M3×4	SCREW M3 L=4	2
49	01	41315001	针板	THROAT PLATE(1790S5)	1
50	02	41315002	针板	THROAT PLATE(1790K5)	1
51		41328023	垫圈	WASHER M4	2
52		41304009	下挡线器座	PICKER BASE	1
53		41312072	下挡线器连接板	PICKER BASE FITTING PLATE	1
54		41312073	旋梭定位钩	STOPPER A	1
55		41304010	定位钩安装板	BOBBIN CASE POSITIONING PLATE	1
56		413S11022	螺钉M3×4	SCREW M3 L=4	1
57		413S13003	螺钉M4×6	SCREW M4 L=6	1
58		413S11024	螺钉M4×10	SCREW M4 L=10	2
59		413S11017	螺钉M4×6	SCREW M4 L=6	1
60		413S12003	螺钉M4×12	SCREW M4 L=12	1
61		413S13010	螺钉M5×8	SCREW M5×0.8 L=8	3
62		413S20013	轴位螺钉	SHOULDER SCREW D8 H2.9	1
63		41327011	弹簧	PICKER SPRING	1
64		41330017	安全开关板	SAFETY SWITCH PRESSING PLATE	1
65		413S11015	螺钉	SCREW	1
66		413S16003	螺母M4	NUT M4	1
67		413S20006	轴位螺钉	SHOULDER SCREW D8 H10	1
68		413S30020	挂簧螺钉	SUSPENSION SCREW	2
69		413S30019	止动销	STOPPER PIN	1
70		4131101400	油箱组件	OIL TANK ASM	1
71		41312074	油箱安装板	OIL TANK PLATE	1
72		413S13008	螺钉M4×8	SCREW	6
73		41312075	止动板	PICKER BASE STOPPER	1
74		413S30021	螺钉	PARTS	1
75		413S30007	螺钉	STUD	1
76		413S11013	螺钉M4×4	SCREW M4 L=4	4
77		41313012	下挡线器	PICKER	1
78		41312076	下挡线传动杆	PICKER ACTUATING LEVER	1
79		41312003	润滑油管固定片	LUBRICATING OIL WICK STOPPER	1
80		41312071	下挡线传动板	PICKER ACTUATING L LINK	1
		NOTE (注解)	01. . .FOR 1790S	1790S用	
			02. . .FOR 1790K	1790K用	

# 9. CLOTH CUTTING KNIFE COMPONENTS

切刀部件

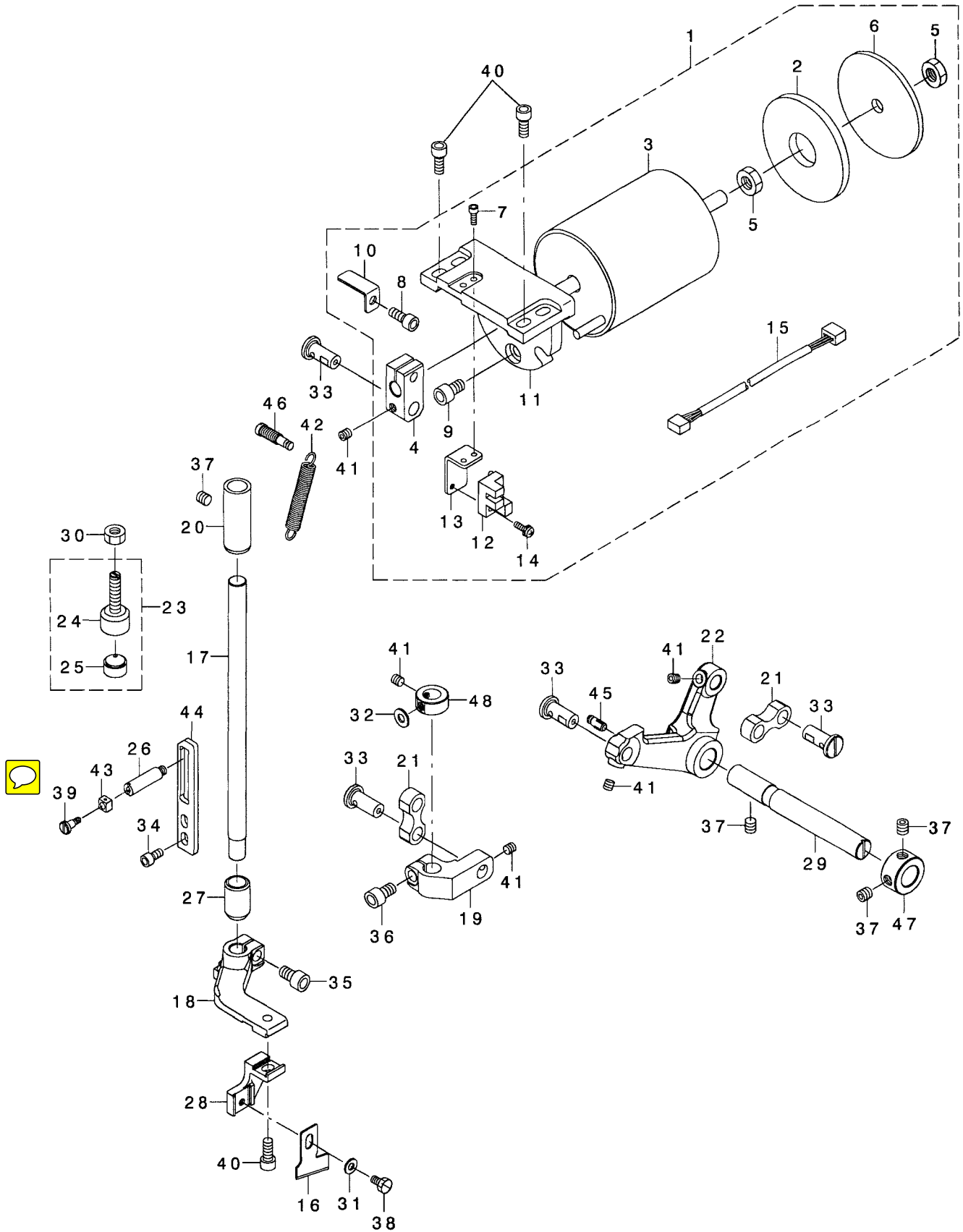

序号 NO	注解 Note	件号 Part NO.	名称	Description	数量 Qty
1		4131900400	切刀驱动组件	KNIFE SOL ASM	1
2		41322006	橡胶缓冲垫	CUSION	1
3		41330018	切刀电磁铁	SOLENOID	1
4		41309007	刀杆座	KNIFE HOLDER	1
5		413S16007	螺母 M8	NUT M8	2
6		41312077	后置板	PLATE A	1
7		413S13022	螺钉M3×8	SCREW M3×0.5 L=8	2
8		413S13019	螺钉M5×12	SCREW M5×0.8 L=12	1
9		413S13005	螺钉M6×10	SCREW M6 L=10	3
10		41312078	传感器安装板	SENSOR SLIT PLATE	1
11		41301009	电磁铁安装座	SOLENOID BASE	1
12		40330005	传感器	PHOTO SENSOR	1
13		41312079	传感器安装板	SENSOR PLATE	1
14		413S13026	螺钉M3×10	SCREW M3×10	1
15		41330020	电线	CUTTER SENSOR JOINT CORD	1
16		40219009	刀片1/2"	KNIFE 1/2	1
17		41302009	切刀轴	KNIFE BAR	1
18		401018	切刀杆座	KNIFE BAR BASE	1
19		41304012	切刀杆支架	KNIFE BAR BRACKET	1
20		41303039	切刀杆上衬套	KNIFE BAR BUSH	1
21		41305005	切刀驱动连杆	KNIFE BAR CONNECTING LINK	2
22		41304013	驱动曲柄	KNIFE BAR DRIVING LEVER	1
23		4132201200	限位螺钉组件	KNIFE BAR DRIVING STOPPER ASM.	1
24		413S30005	切刀限位螺钉	KNIFE BAR DRIVING STOP SCREW	1
25		41322007	缓冲垫	KNIFE DRIVING LEVER STOPPER	1
26		41326030	支撑轴	KNIFE BAR SUPPORT SHAFT	1
27		41303040	切刀杆下衬套	KNIFE BAR LOWER BUSHING	1
28		41304014	切刀安装座	KNIFE FITTING BASE	1
29		41302010	驱动轴	KNIFE LEVER SHAFT	1
30		413S16006	螺母 M6	NUT M6	1
31		41328010	垫圈	WASHER 4.3×9×0.8	1
32		41328016	垫圈	WASHER 5×10.5×1	1
33		41326031	曲柄轴	BELL CRANK SHAFT	4
34		413S13016	螺钉M4×8	SCREW M4×0.7 L=8	2
35		413S13023	螺钉M6×12	SCREW M6 L=12	1
36		413S13023	螺钉M6×12	SCREW	1
37		413S14001	螺钉M6×6	SCREW M6 L=6	4
38		413S12004	螺钉M4×6	HEXAGONAL BOLT	1
39		413S20010	切刀导向轴位螺钉	SHOULDER SCREW D4 H5	1
40		413S13019	螺钉M5×12	SCREW M5×0.8 L=12	5
41		207S14006	螺钉	SCREW M5 L=5	5
42		41327012	弹簧	SPRING	1
43		41309008	滑块	SQUARE BLOCK	1
44		41312080	支撑导向板	SUPPORT GUIDE	1
45		41326033	挂簧销	SUSPENSION SCREW	1
46		413S30013	挂簧螺钉	SUSPENSION SCREW	1
47		41303041	驱动轴挡圈	THRUST COLLAR D=12 W=11	1
48		41303042	切刀杆支架挡圈	COLLAR	1

# 10. TABLE COMPONENTS

台板部件

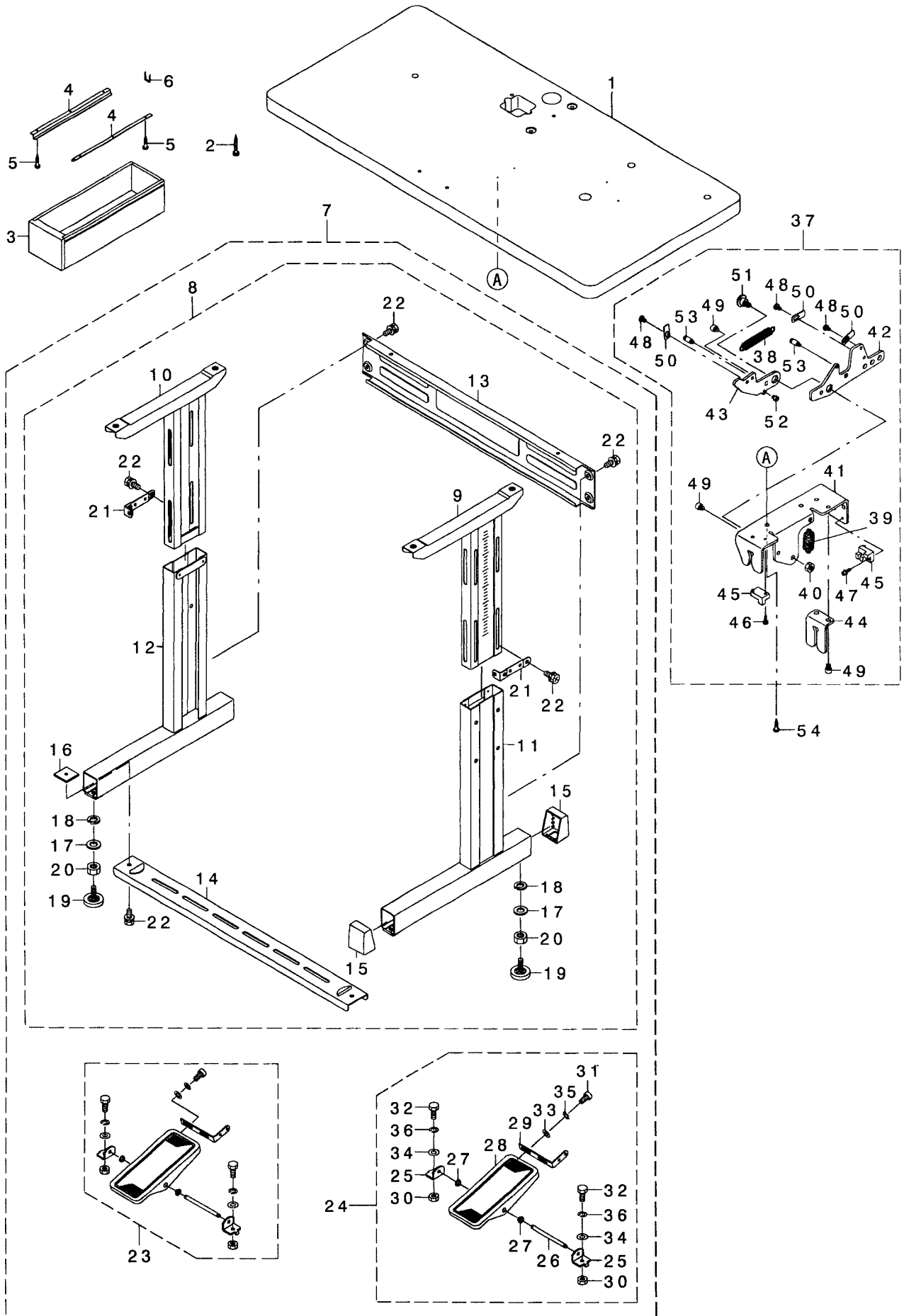

序号 NO	注解 Note	件号 Part NO.	名称	Description	数量 Qty
1		702054	台板	TABLE	1
2		-----	白攻螺钉	TAPPING SCREW M5×35	4
3		-----	抽屉	DRAWER	1
4		-----	抽屉支架	DRAWER SUPPORT	2
5		-----	木螺钉	WOOD SCREW D=3.1 L=16	6
6		-----	抽屉挡板	DRAWER STOPPER	1
7		702052	桌脚部分	T-STAND COMPL	1
8		-----	桌脚组件	T-STAND ASM.	1
9		-----	右桌脚上支架	UPPER STAND ASM., RIGHT	1
10		-----	左桌脚上支架	UPPER STAND ASM., LEFT	1
11		-----	右桌脚下支架	LOWER LEG, RIGHT	1
12		-----	左桌脚下支架	LOWER LEG, LEFT	1
13		-----	桌脚横撑	STAND SIDE SUPPORT	1
14		-----	桌脚横撑	STAND SIDE SUPPORT	1
15		-----	橡胶套	RUBBER CAP	4
16		-----	螺母	NUT	2
17		-----	垫片	WASHER M12	4
18		-----	弹簧垫片	SPRING WASHER 12.5×21.5×3	4
19		-----	带垫调节螺钉	ADJUSTING SCREW ASM. WITH CAP	4
20		-----	螺母M12	NUT M12	1
21		-----	调节压板	UPPER STAND PLATE	2
22		-----	螺钉	WASHER HEXAGONAL BOLT	12
23		-----	踏板组件	Z-STAND PEDAL ASM	1
24		-----	踏板组件	Z-STAND PEDAL ASM	1
25		-----	踏板支架	PEDAL SHAFT BRACKET	2
26		-----	踏板连接轴	PEDAL CONNECTING ROD	1
27		-----	踏板轴衬	PEDAL BUSHING	2
28		-----	踏板	PEDAL ASM.	1
29		-----	踏板调节板	PEDAL ADJUSTING PLATE	1
30		-----	螺母	NUT M8	2
31		-----	螺钉M6×12	SCREW M6 L=12	2
32		-----	螺钉M8×20	SCREW M8 L=20	2
33		-----	垫片	WASHER 6.7×13×1	2
34		-----	垫片	WASHER 8.7×18×1.6	4
35		-----	弹簧垫片	SPRING WASHER 6.2×11.4×1.2	2
36		-----	弹簧垫片	SPRING WASHER 8.6×15×1.4	2
37		4133002800	电控开关组件	ASSY 4 POSITION PEDAL	1
38		41327013	弹簧	SPRING	1
39		41327014	弹簧	SPRING	1
40		413S16005	螺母M6	NUT M6	1
41		41312092	电控开关固定架	PEDAL FRAME	1
42		41312093	电控开关A	PEDAL FRAME A	1
43		41312094	电控开关B	PEDAL FRAME B	1
44		41312095	传感器固定架	PEDAL FRAME GUIDE	1
45		40330005	传感器	PHOTO SENSOR	2
46		403S11041	螺钉组件	SCREW M3×10	1
47		413S13027	螺钉组件	SCREW	1
48		S04010	螺钉	SCREW	3
49		413S13001	螺钉M5×6	HEXAGON SOCKET HEAD SCREW M5×6	4
50		41312096	传感器检测板	SENSOR DETECTING PLATE	3
51		413S20012	轴位螺钉	SHOULDER SCREW D10 H6.4	1
52		413S30019	止动销	STOPPER PIN	1
53		413S30020	挂簧螺钉	SUSPENSION SCREW	2
54		S05035	木螺钉	WOOD SCREW D=4.8 L=20	2

11. CONTROL BOX COMPONENTS  
控制箱关系

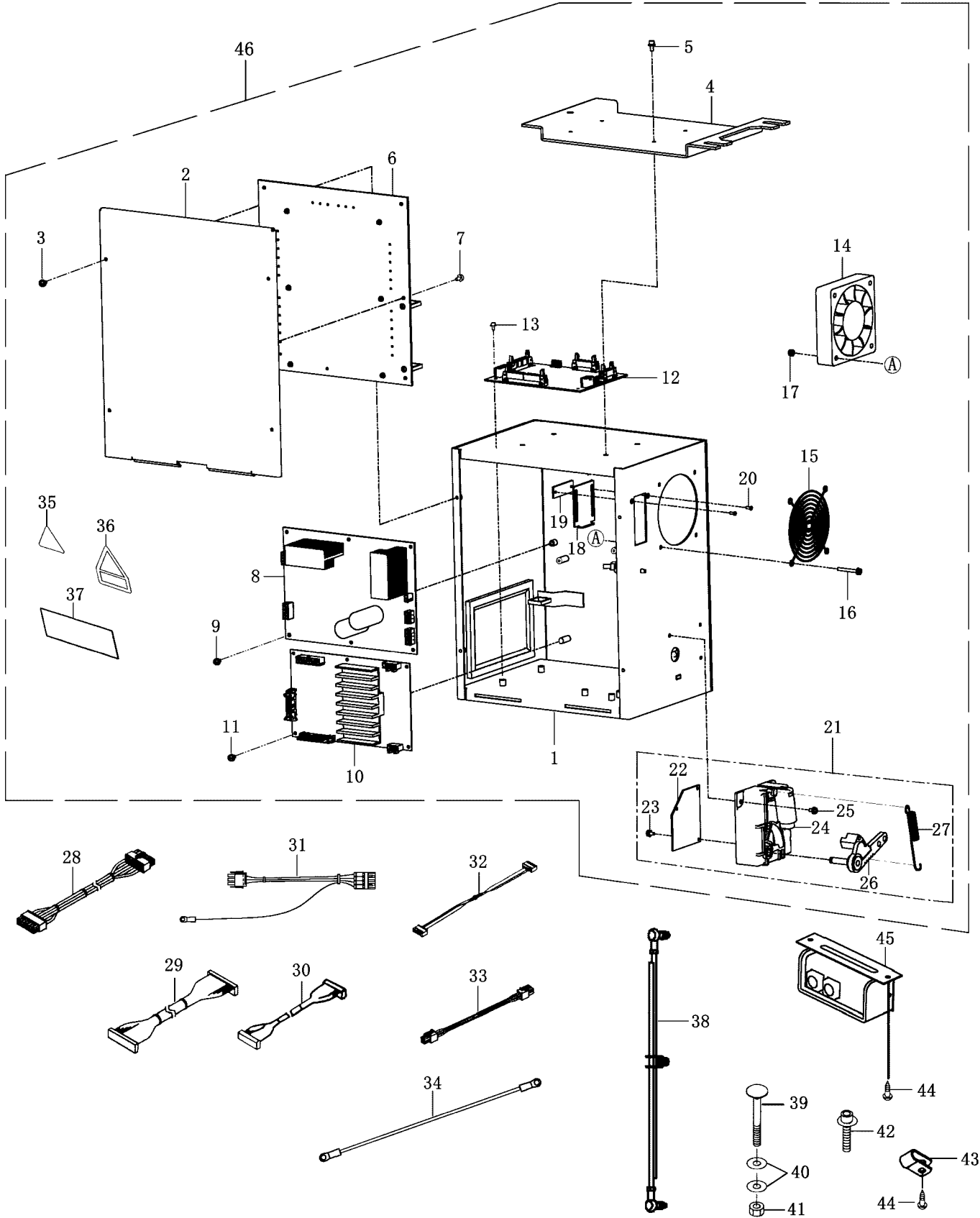

序号 NO	注解 Note	件号 Part NO.	名称	Description	数量 Qty
1		41312116	电控箱	CONTROL BOX	1
2		41312117	前盖板	CONTROL BOX FRONT COVER	1
3		413S11031	螺钉	SCREW	4
4		41312118	电控箱安装板	CONTROL BOX FITTING PLATE	1
5		413S11032	螺钉	SCREW	4
6		41330034	步进驱动	STEP DRIVER	1
7		413S11033	螺钉	SCREW	6
8		41330035	电源板	POWER BOARD	1
9		413S11033	螺钉	SCREW	6
10		41330036	主轴驱动	MAIN AXIS DRIVER	1
11		413S11033	螺钉	SCREW	6
12		41333037	系统板	SYSTEM BOARD	1
13		413S11033	螺钉	SCREW	4
14		41330040	风扇	FAN MOTOR ASS'Y	1
15		41312119	风扇挡板	FINGER GUIDE	1
16		413S11034	螺钉	SCREW	4
17		413S16014	螺母	NUT	4
18		41312120	电线挡板	CORD FITTING PLATE	1
19		41312121	固定板	FITTING PLATE	1
20		413S11035	螺钉	SCREW	2
21		4133005800	脚踏传感器组件	PEDAL SENSOR ASM	1
22		41330041	脚踏接口板	PEDAL INTERFACE BOARD	1
23		413S11036	螺钉	SCREW	3
24		41311016	脚踏传感器底座	PEDAL SENSOR BASE	1
25		413S11037	螺钉	SCREW	3
26		41301028	踏杆	PEDAL LEVER	1
27		41327022	弹簧	FRONT SPRING	1
28		41330042	系统电源电缆	SYSTEM POWER CABEL	1
29		41330043	步进信号电缆	STEPPER MOTOR SIGNAL CABEL	1
30		41330044	主轴信号电缆	MAIN AXIS SIGNAL CABEL	1
31		41330045	主轴电源电缆	MAIN AXIS POWER CABEL	1
32		41330046	脚踏电缆	PEDAL CABEL	1
33		41330047	步进电源电缆	STEPPER MOTOR POWER CABEL	1
34		41330048	接地线	EARTH CABLE ASM	1
35		41337004	电压警告标签	VOLTAGE WARING LABEL	1
36		41337005	电压提示标签	VOLTAGE CAUTION LABEL	1
37		41337006	铭牌	RATING LABEL	1
38		4133102000	脚踏连杆	CONNECTING ROD ASM	1
39		401S30019	螺栓	BOLT	2
40		W01018	垫片	WASHER	4
41		401S16018	螺母	NUT	2
42		403S13020	螺钉	SCREW	3
43		40311016	线夹	CABLE CLAMP	3
44		S05035	木螺钉	WOOD SCREW	5
45		41330049	电源开关	SWITCH	1
46		4133003000	控制箱组件	CONTROL BOX ASSY	1



## 12. OPERATION BOX COMPONENTS

### 操作面板部件

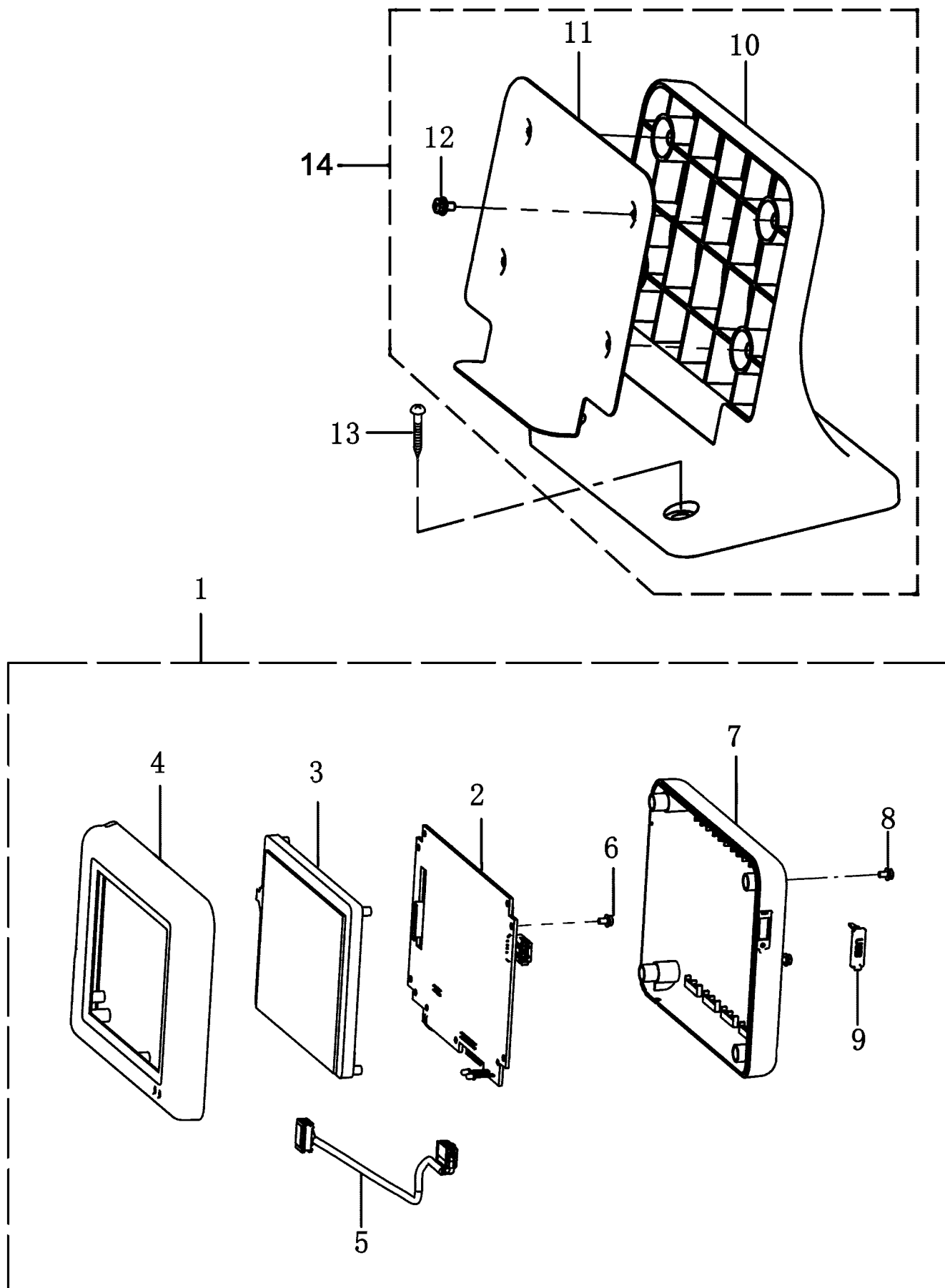

序号 NO	注解 Note	件号 Part NO.	名称	Description	数量 Qty
1		4133003100	操作面板组件	OPERATION PANEL ASS'Y	1
2		41330059	面板电路板	PANEL PCB ASS'Y	1
3		41330060	液晶屏	LCD	1
4		41330061	操作面板前盖	OPERATION_PANEL_F	1
5		41330062	液晶屏电缆	LCD CABEL	
6		413S11039	螺钉	SCREW	4
7		41330064	操作面板后盖	OPERATION_PANEL_R	1
8		413S11040	螺钉	SCREW	4
9		41330066	USB接口盖	USB_COVER	1
10		41311017	操作面板固定底座	OPERATION BOX FIXED BASE	1
11		41312122	固定板	FIXED PLATE	1
12		413S11038	螺钉	SCREW	4
13		S05035	木螺钉	WOOD SCREW	2
14		4133006700	操作面板固定座组件	OPERATION BOX FIXED PLATE ASM.	1

# 13. WIRING DIAGRAM 电装配线图

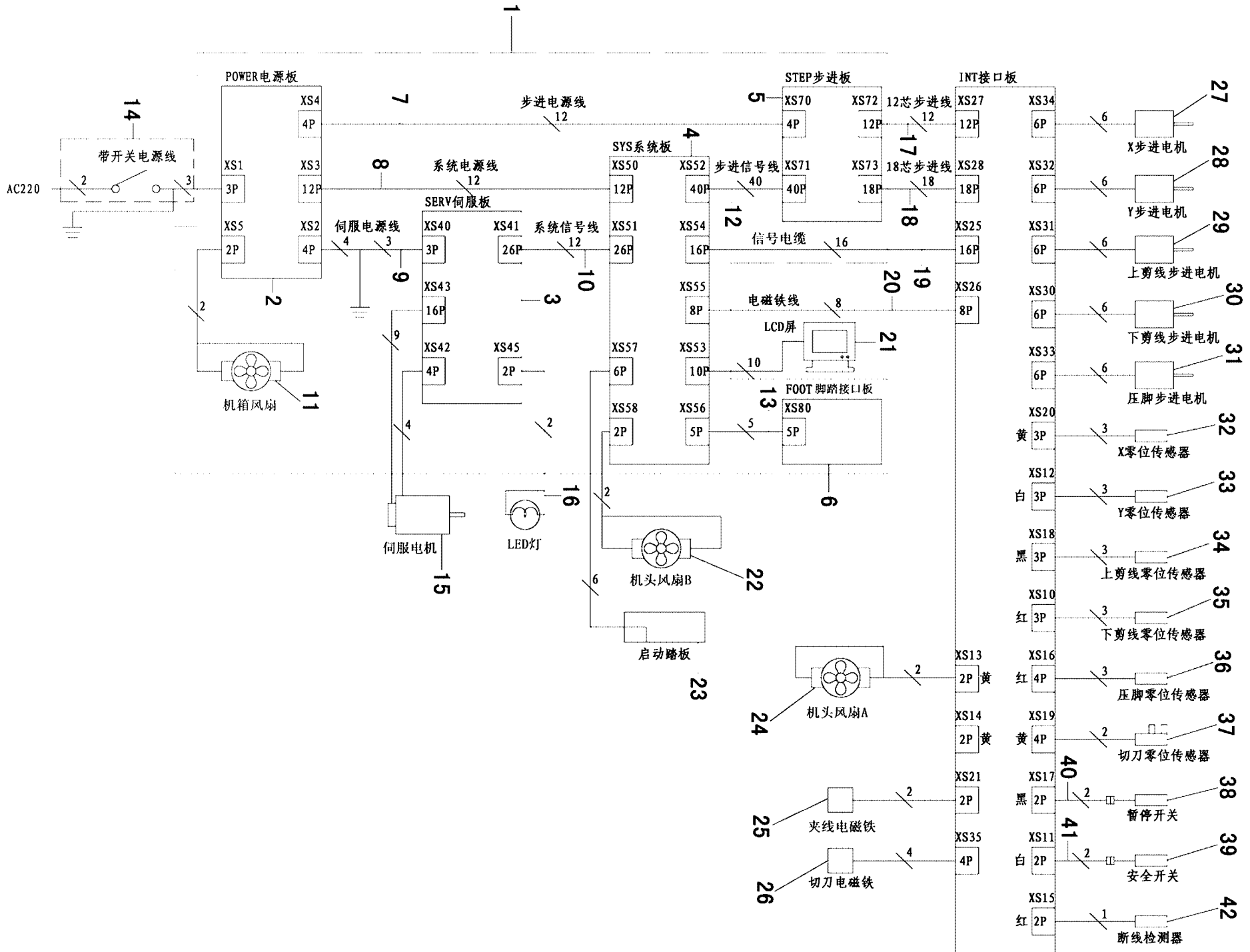

序号 NO	注解 Note	件号 Part NO.	名称	Description	数量 Qty
1		41312116	电控箱	CONTROL BOX ASM	1
2		41330035	电源板	POWER BOARD	1
3		41330036	主轴驱动	SERVO BOARD	1
4		41330037	系统板	SYSTEM BOARD	1
5		41330034	步进驱动	STEP BOARD	1
6		41330041	脚踏接口板	PEDAL INTERFACE BOARD	1
7		41330047	步进电源线	STEPPER MOTOR POWER CABEL	1
8		41330042	系统电源线	SYSTEM POWER CABEL	1
9		41330045	伺服电源线	SERVO POWER CABEL	1
10		41330068	系统信号线	SYSTEM SIGNAL CABEL	1
11		41330040	机箱风机	FAN MOTOR ASS'Y	1
12		41330043	步进信号线	STEPPER MOTOR SIGNAL CABEL	1
13		41330046	脚踏线	PEDAL CABEL	1
14		41330049	电源开关	SWITCH	1
15		41330006	伺服电机	SERVO MOTOR	1
16		41330033	LED灯	LED	1
17		41330039	12芯步进线	INT CORD B ASS'Y	1
18		41330023	18芯步进线	INT CORD A ASS'Y	1
19		41330024	信号电缆	INT CORD D ASS'Y	1
20		41330020	电磁铁线	INT CORD C ASS'Y	1
21		4133003100	LCD屏	LCD	1
22		41330004	桌板风扇	HEAD FAN MOROR	1
23		4133002800	启动踏板	STARTUP PEDAL	1
24		41330002	机头风扇	HEAD FAN MOROR	1
25		41330005	夹线电磁铁	ASSY-AT-SOLENOID	1
26		41330018	切刀电磁铁	SOLENOID	1
27		41330012	X步进电机	NEEDLE SWING MOTOR	1
28		41330007	Y步进电机	FEED MOTOR	1
29		41330013	上剪线步进电机	UT TRIM MOTOR	1
30		41330015	下剪线步进电机	LT TRIM MOTOR	1
31		41330009	压脚步进电机	CLAMP MOTOR	1
32		41330011	X零位传感器	NEEDLE SWING SENSOR ASSY	1
33		41330008	Y零位传感器	FEED SENSOR ASS'Y	1
34		41300014	上剪线零位传感器	UT TRIM SENSOR ASS'Y	1
35		41330016	下剪线零位传感器	LT TRIM SENSOR ASS'Y	1
36		41330010	压脚零位传感器	CLAMP SENSOR ASS'Y	1
37		40330005	切刀零位传感器	PHOTO SENSOR	1
38		4133000300	暂停开关	SWITCH ASM	1
39		4133000400	安全开关	SAFETY SWITCH ASS'Y	1
40		41330069	暂停开关线	SWITCH CORD ASS'Y	1
41		41330021	安全开关线	SAFETY SWITCH CORD ASS'Y	1
42		41312018	断线检测器	THREAD BREAK DETECTOR A	1

14. ACCESSORIE PART COMPONENTS

附件

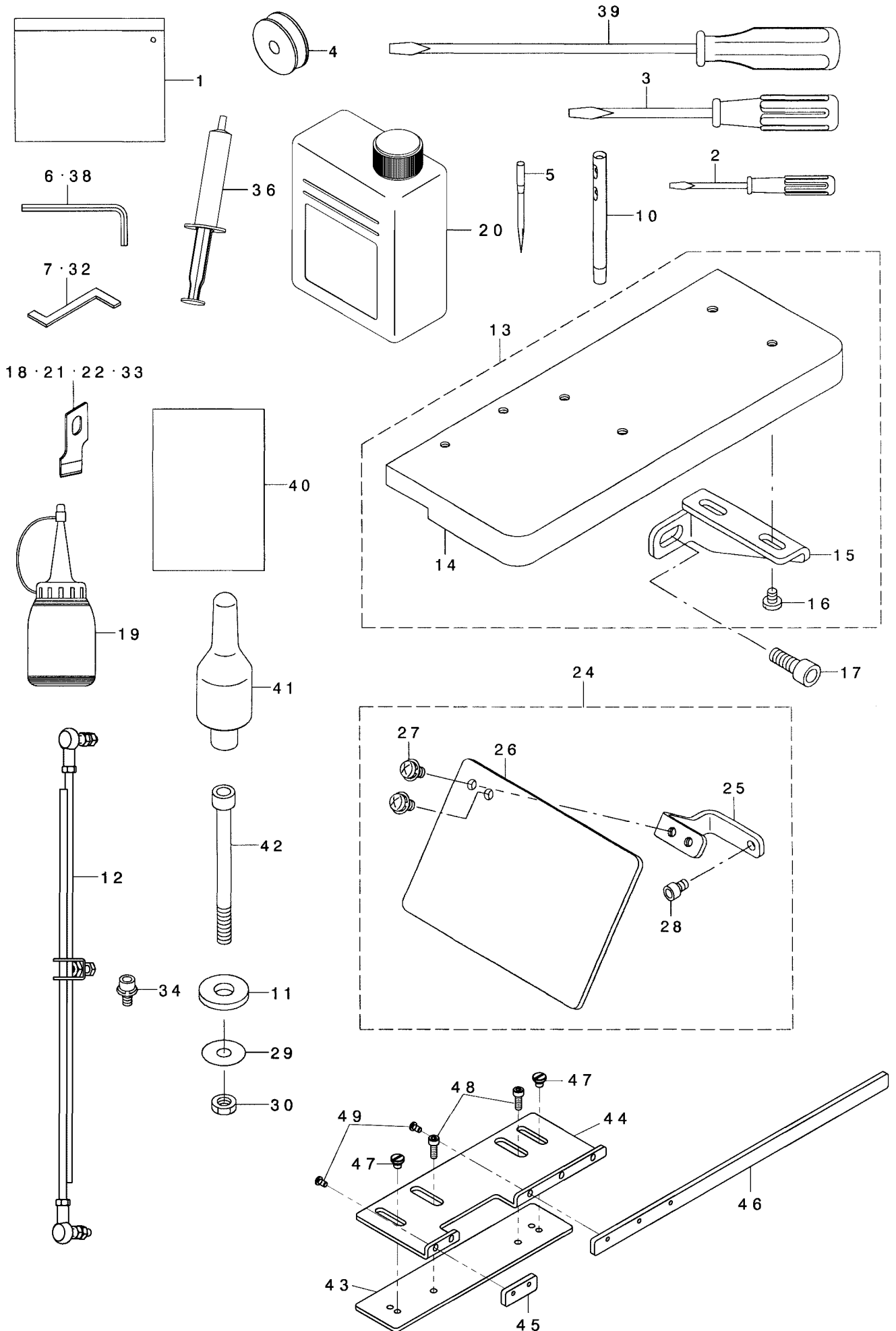

序号 NO	注解 Note	件号 Part NO.	名称	Description	数量 Qty
1		40131017	机头罩	ACCESSORIE BAG	1
2		10131004	一字螺丝刀 (小)	SCREW DRIVER, SMALL	1
3		10131003	一字螺丝刀 (中)	SCREW DRIVER, MIDDLE	1
4		4021800200	梭心	BOBBIN	1
5		40217002	机针#12	NEEDLE DP×5 #12 J-2	1
6		20131056	内六角扳手	HEXAGONAL WRENCH KEY	1
7	01	41312097	定时调节钩	HOOK TIMING GAUGE, K	1
8		-----			
9		-----			
10		41313013	过线轴	THREAD GUIDE BAR	1
11		41322003	垫圈	RUBBER CUSHION(B)	4
12		4133100600	连接杆组件	CONNECTING ROD COMPL.	1
13		4130101200	辅助桌板组件	AUXILIARY TABLE ASM.	1
14		301651	辅助桌板	AUXILIARY TABLE	1
15		41312090	托架	INSTALLING PLATE	2
16		413S11025	螺钉	SCREW 11/64-40 L=4.8	4
17		413S13005	螺钉M6×10	SCREW M6 L=10	2
18		40219012	切刀 1"	KNIFE 1	1
19		20131038	油壶组件	OILER	1
20		20131037	油壶组件	DEFRIX OIL NO. 1	1
21		40219010	切刀5/8"	KNIFE 5/8	1
22		40219009	切刀1/2"	KNIFE 1/2	1
23		-----			
24		4133100700	护眼板组件	ASSY SAFETY PLATE B	1
25		41312099	护眼板托架	SAFETY PLATE BESE	1
26		40911006	安全板	SAFETY PLATE	1
27		413S11028	螺钉组件	SCREW M4 L=8	2
28		413S13003	螺钉M4×6	SCREW M4 L=6	1
29		41328001	垫片	WASHER 6.1×18.5×2	4
30		413S16005	螺母M6	NUT M6	4
31		-----			
32	02	41312100	定时调节钩	TIMING GAUGE, DMESTIC USE.	1
33		40219011	切刀3/8"	KNIFE 3/8	1
34		413S13008	螺钉组件	BOLT	1
35		-----			
36		11411029	润滑脂	GREASE A TUBE	1
37		-----			
38		30131012	内六角扳手	HEXAGONAL SPANNER	1
39		10131002	螺丝刀(大)	SCREW DRIVER, LARGE	1
40		41313014	说明书	EC PRODUCTION DECLARATION	1
41		40311002	机头支撑柱	HEAD SUPPORT BAR	1
42		413S13006	螺栓M6×70	HEXAGON BOLT	4
43		41312123	安装座	FIXED PLATE	1
44		41312124	调节板	ADJUSTING PLATE	1
45		41312125	挡板1	BAFFLE PLATE 1	1
46		41312126	挡板2	BAFFLE PLATE 2	1
47		403S20016	轴位螺钉	SHOULDER SCREW	2
48		413S13011	螺钉	SCREW	2
49		401S11003	螺钉	SCREW	5
NOTE (注解)					
		01. . . FOR 1790S		1790S用	
		02. . . FOR 1790K		1790K用	

# 15. THREAD STAND COMPONENTS

## 线架部件

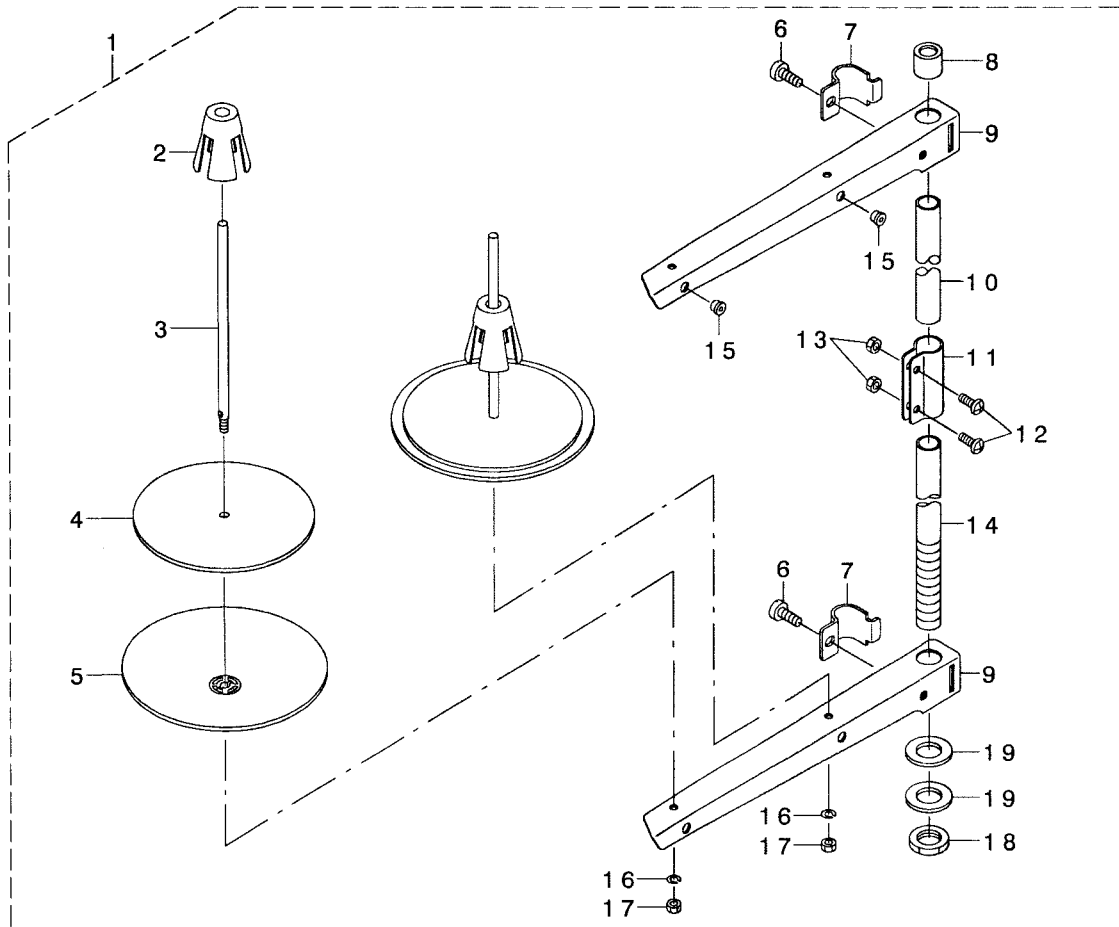

REF. NO	NOTE	PART NO.	名称	DESCRIPTION	Qty
1		1013100700	过线架组件	THREAD STAND ASM.	1
2		-----	线架缓冲支架	SPOOL RETAINER	(2)
3		-----	线轴	SPOOL PIN	(2)
4		-----	线盘软垫	SPOOL REST CUSHION	(2)
5		-----	线盘	SPOOL REST	(2)
6		-----	螺钉	SCREW M6 L=16	(2)
7		-----	过线架固定夹	THREAD GUIDE ARM JOINT	(2)
8		-----	线架支撑套	SPOOL REST ROD RUBBER CAP	(1)
9		-----	线架	SPOOL REST ARM	(2)
10		-----	线架支撑管 1	SPOOL REST ROD, UPPER	(1)
11		-----	支撑管接头	SPOOL REST ROD JOINT	(1)
12		-----	螺钉	SCREW M5 L=14	(2)
13		-----	螺母	NUT M5	(2)
14		-----	线架支撑管 2	SPOOL REST ROD, LOWER	(1)
15		-----	过线套	THREAD GUIDE	(2)
16		-----	弹簧垫圈	SPRING WASHER	(2)
17		-----	螺母	NUT M5	(2)
18		-----	螺母	NUT M16X1.5	(1)
19		-----	垫片	WASHER 17X30X2.6	(2)

# 16. EXCHANGING PARTS

## 交换零件

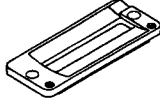
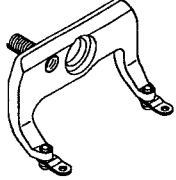
Cloth Cutting Knife 切刀		Presser Foot (Length of Cloth Cutting Knife) 压脚 (切刀长度)			Presser Foot (Presser Size) 压脚(压脚尺寸)	
						
标准 Standard		标准 Standard	针织用 For Hoisiery	标准(摆幅6MM) Standard (For swing width 6mm)	标准 Standard	
inch	mm	Ref. no	Ref. no	Ref. no	Ref. no	
1/4	6.4	1	12 (6.4 ~ 19.1 mm)	15 (6.4 ~ 19.1 mm)	18 (6.4 ~ 31.8 mm)	19 (Type 1)
3/8	9.5	2				
7/16	11.1	3				
1/2	12.7	4				
9/16	14.3	5				
5/8	15.9	6				
11/16	17.5	7				
3/4	19.1	8	13 (6.4 ~ 25.4 mm)	16 (6.4 ~ 25.4 mm)	20 (Type 2)	
7/8	22.2	9				
1	25.4	10				
1-1/4	31.8	11	14 (6.4 ~ 31.8mm)	17 (6.4 ~ 31.8 mm)	21 (Type 3)	

REF. NO	NOTE	PART NO.	名称	DESCRIPTION	Qty
1		-----	刀片 1/4"	KNIFE 1/4"	1
2		40219011	刀片 3/8"	KNIFE 3/8	1
3		-----	刀片 (7/16)	KNIFE (7/16)	1
4		40219009	刀片 1/2"	KNIFE 1/2	1
5		-----	刀片 9/16"	KNIFE 9/16"	1
6		40219010	刀片 5/8"	KNIFE 5/8	1
7		-----	刀片 11/16"	KNIFE 11/16	1
8		-----	刀片 3/4"	KNIFE 3/4"	1
9		-----	刀片 7/8"	KNIFE 7/8"	1
10		40219012	刀片 1"	KNIFE 1	1
11		40219013	刀片 1-1/4"	KNIFE 1-1/4"	1
12		-----	压脚板	PRESSER	1
13		-----	压脚板 2	WORK CLAMP CHECK, 2	1
14		-----	压脚板 3	WORK CLAMP CHECK, 3	1
15		-----	压脚板	LATCH WORK CLAMP CHECK	1
16		-----	压脚板 (2K)	WORK CLAMP CHECK (2K)	1
17		-----	压脚板 (3K)	WORK CLAMP CHECK (3K)	1
18		-----	压脚板	WORK CLAMP CHECK	1
19		-----	压脚板支架组件	WORK CLAMP CHECK HOLDER ASM.	1
20		-----	压脚支架	WORK CLAMP CHECK HOLDER	1
21		-----	压脚支架	WORK CLAMP CHECK HOLDER	1



# 17. SPECIAL SPECIFICATIONS COMPONENTS

特殊类型部件

LARGE SIZE TYPE (FOR 70MM, 120MM)  
大尺寸类型 (70MM, 120MM用)

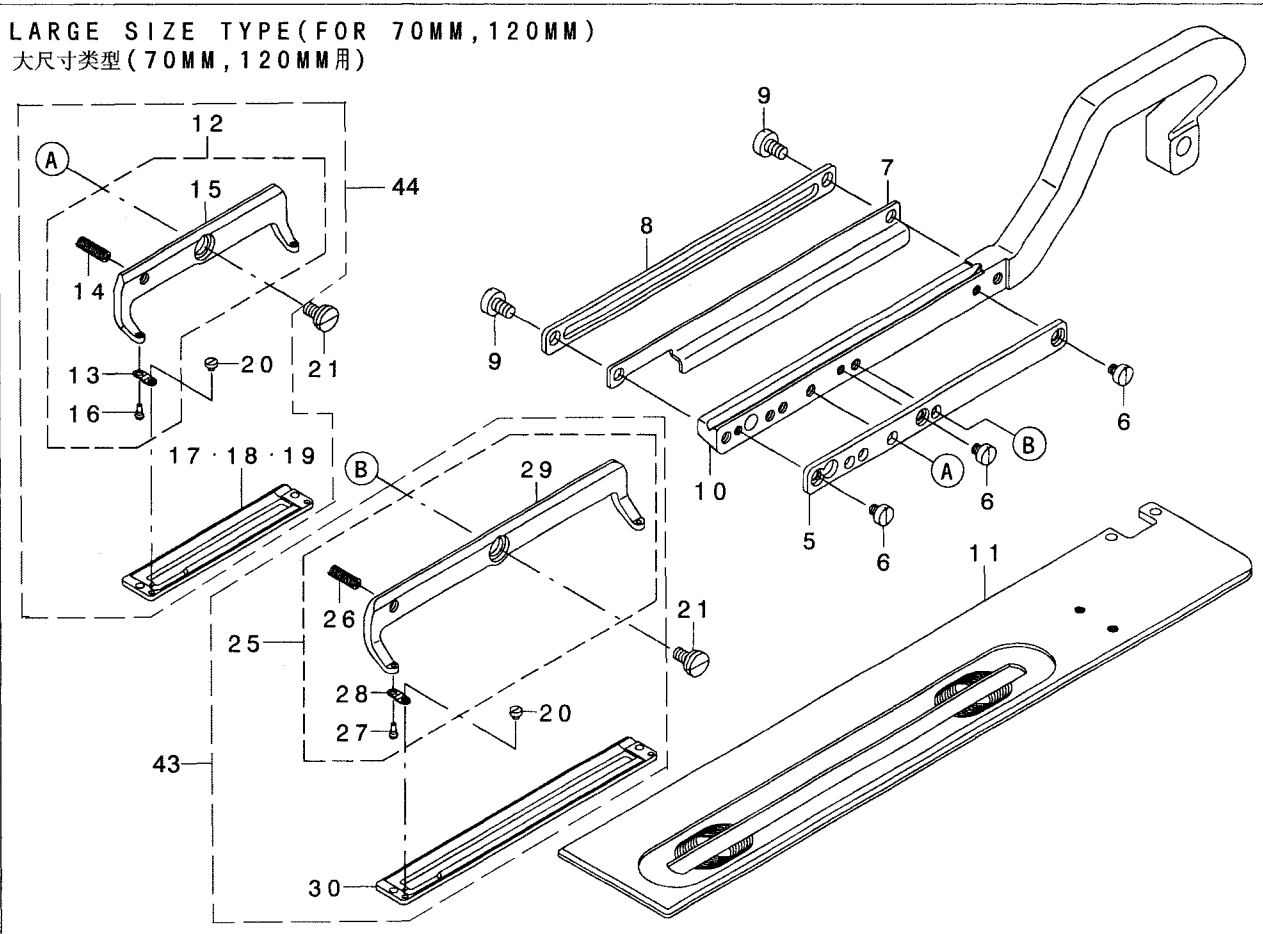

SWING WIDTH 10MM TYPE  
摆动宽度10MM类型

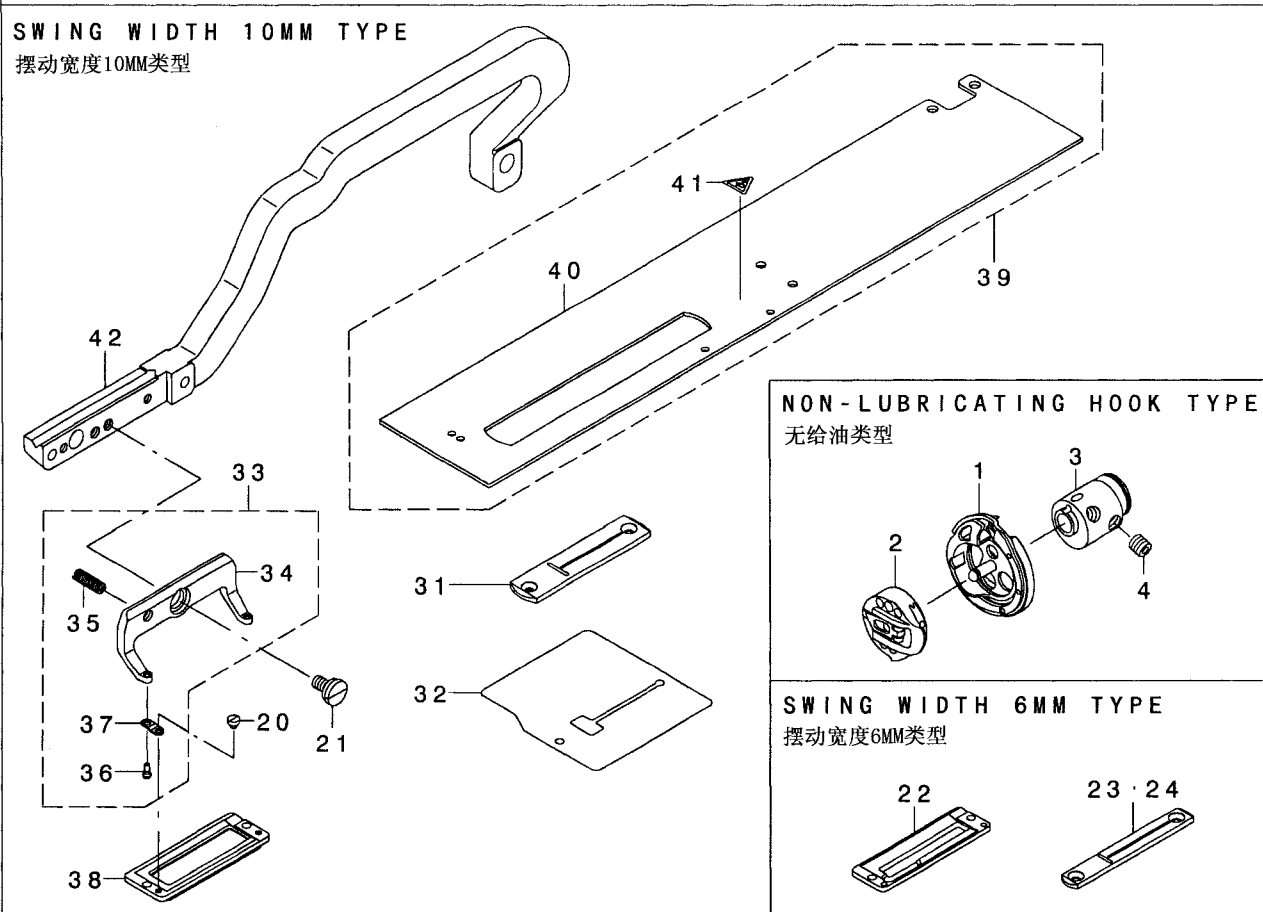

NON-LUBRICATING HOOK TYPE  
无给油类型

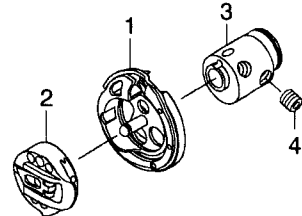

SWING WIDTH 6MM TYPE  
摆动宽度6MM类型

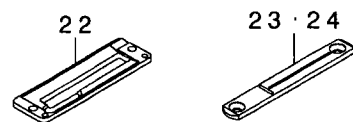

序号 NO	注解 Note	件号 Part NO.	名称	Description	数量 Qty
1		41318004	旋梭	RP_HOOK_ASM	1
2		41318005	梭壳	RP_BOBBLN_CASE	1
3		4130304300	旋梭连接套组件	HOOK_SLEEVES	1
4		413S14011	螺钉	SCREW 1/4-40 L=6	4
5	01	41312103	压脚板座垫片	WORK_CLAMP HOLDER SPACE	1
6	01	413S11013	螺钉	SCREW M4 L=4	3
7		41312104	剪线板	UTT_CLOSE_CAM_120B	1
8		41312105	压脚送料导向板	LIFTING_PLATE_120	1
9		413S11018	螺钉M5×8	SCREW M5 L=8	2
10		41316007	压脚支架	WORK_CLAMP_ARM_120	1
11		401218	送布拖板	WORK_CLAMP_CARRIER_120	1
12	01	4131600200	压脚组件(70)	PRESSER FOOT 70 ASM.	1
13		40212018	压脚弹簧板	PRESSER FITTING PLATE SPING	2
14		40227003	压脚板座弹簧	PRESSER FOOT HOLDER SPRING	1
15		41316003	压脚板座(70)	PRESSER FOOT 70	1
16		40226008	压脚弹簧定位销	BRESSER FOOT PIN B	2
17	01	41316004	压脚板	URETHANE PRESSER 70	1
18	01	41316005	压脚板	PRESSER 70 (FLAT)	1
19	01	41316006	压脚板	PRESSER70	1
20		413S11029	螺钉	SCREW 3/32-56 L=1.9	6
21	01	402S20002	压脚螺钉	HINGE SCREW D=7.94 H=2	3
22	02	41316008	压脚板	PRESSER 6MM	1
23	02	41315003	针板(S6)	THROAT_PLATE(S6)	1
24	02	41315004	针板(K6)	THROAT_PLATE(K6)	1
25	03	4131600900	压脚组件(120)	ASSY WORK_CLAMP_CHECH HOLDER I	1
26		41327018	压脚板座弹簧	WORK_CLAMP_CHECK HOLDER SPRING	1
27		41326035	压脚弹簧定位销	WORK_CLAMP_CHECK SPRING SET PI	2
28		41312109	压脚弹簧板	WORK_CLAMP_CHECK SPRING	2
29		41316010	压脚板座(120)	WORK_CLAMP_CHECK HOLDER_120	1
30	03	41316011	压脚板(120)	WORK_CLAMP_120	1
31	04	41315005	针板(S10)	THROAT_PLATE(S10)	1
32	04	41312107	防油板	OIL_SHIELD_10	1
33	04	4131601200	压脚(3-10)组件	WORK_CLAMP HOLDER(3-10_ASSY)	1
34		41316013	压脚板座(3-10)	WORK_CLAMP HOLDER(3-10_ASSY)	1
35		41327018	压脚板座弹簧	WORK_CLAMP_CHECK HOLDER SPRING	1
36		40226008	压脚弹簧定位销	WORK_CLAMP_CHECK SPRING SET PI	2
37		40212018	压脚弹簧板	WORK_CLAMP_CHECK SPRING	2
38	04	41316014	压脚板(3S-10)	WORK_CLAMP(3S-10)	1
39	04	-----	送布拖板组件	WORK_CLAMP CARRIER(10×41) CL	1
40		41312108	送布拖板(10×41)	WORK_CLAMP CARRIER(10×41)	1
41		41337002	注意标签	ATTENTION SEAL	1
42	04	41316015	压脚支架(10×41)	WORK_CLAMP_ARM(10×41)	1
43		4131601000	压脚组件	WORK_CLAMP_CHECK HOLDER ASM	
44		4131602800	压脚组件	WORK_CLAMP_CHECK HOLDER ASM	

NOTE (注解): 01.....FOR PRESSER 70MM 70MM压脚用  
02.....FOR SWING WIDTH 6MM 摆动宽度6MM用  
03.....FOR PRESSER 120MM 120MM压脚用  
04.....FOR SWING WIDTH 10MM 摆动宽度10MM用